



AUXSOL

WIN GREEN FUTURE TOGETHER

INSTALLATION OPERATION MANUAL

ASN series

ASN - (3.6~5)SL

ASN - (3.6~6)SL - PLUS

AUXSOL

WIN GREEN FUTURE TOGETHER

Ningbo AUX Solar Technology Co., Ltd.

No.17 Fenglin Road, Cicheng Town,
Jiangbei District, Ningbo City, Zhejiang Province, China

✉ info@auxsol.com

🌐 www.auxsol.com

☎ +86 0574-8765 2201

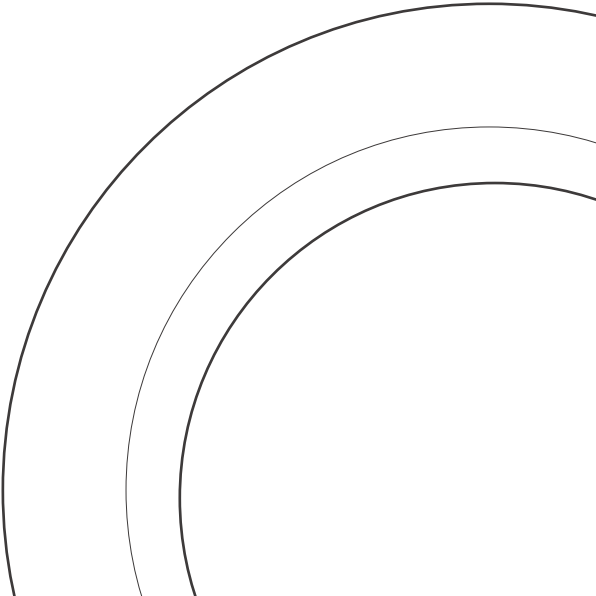

Ningbo AUX Solar Technology Co., Ltd.

CONTENT

PREFACE

Summary	1
Applicable products	1
Applicable staff	1
Symbol definition	1

1 OPEN THE CARTON TO CHECK

1.1 Inspection before acceptance	2
1.2 Packing list	2
1.3 Storage	3

2 SAFETY PRECAUTIONS

2.1 General safety	4
2.2 PV string safety	4
2.3 Inverter safety	5
2.4 Personnel requirements	5

3 INTRODUCTION

3.1 Products introduction	6
3.2 Outlook introduction	6
3.3 Dimension	7
3.4 Display description	7

PREFACE

4 APPLICATION

4.1 Application scenario	16
4.2 Application mode	17
4.3 Function characteristics	17

5 INSTALLATION

5.1 Installation requirements	18
5.2 Installation of inverter	21
5.3 Electrical connection	22

6 EQUIPMENT COMMISSIONING AND MAINTENANCE

6.1 Check before power-on	30
6.2 Power on the equipment	30
6.3 Set inverter parameters via APP	31
6.4 Power off the equipment	31
6.5 Equipment removal	32
6.6 Equipment scrapping	32
6.7 Trouble shooting	32
6.8 Regular maintenance	39

7 TECHNICAL PARAMETER

40

Summary

This document mainly introduces the installation, electrical connection, adjustment, maintenance and troubleshooting methods of ASN series single-phase on grid solar inverter. Before installing and using the inverter, please read this manual carefully to understand the safety information and get familiar with the functions and characteristics of the inverter. The document may be updated from time to time. Please obtain the latest version of the information and other product information from the official website.

Applicable products

This document is applicable to the following of ASN series single-phase on grid inverter:

ASN-(3.6~5)SL

ASN-(3.6~6)SL-PLUS

Applicable staff

It is only applicable to professionals who are familiar with local regulations and standards and electrical system, have received professional training and are familiar with the relevant knowledge of the product.

Symbol definition

To better use this manual, the following symbols are used to highlight important information. Please read the symbols and instructions carefully.



Danger:

Indicates a highly potential danger that, if not avoided, could result in death or serious injury to personnel.



Warning:

Indicates a moderate potential hazard, which could lead to death or serious injury if not avoided.



Watch out:

Indicates a low level of potential danger that, if not avoided, may result in moderate or mild injury to personnel.



Watch out:

Emphasizing and supplementing the content may also provide tips or tricks for optimizing product usage, which can help you solve a problem or save your time.

1 OPEN THE CARTON TO CHECK

1.1 Inspection before acceptance

Before signing for the product, please carefully check the following contents:

- Check the outer packaging for any damage, such as deformation, holes, cracks, or other signs that may cause damage to the equipment inside the packaging. If there is any damage, do not open the packaging and contact your dealer.
- Check if the inverter model is correct. If there is any discrepancy, do not open the packaging and contact your dealer.
- Check whether the type and quantity of delivered items are correct, and whether there is any damage to the appearance. If there is any damage, please contact your dealer.

1.2 Packing list



Watch out:

- The number of PV DC input terminals matches the number of inverter DC input terminals.
- The datalogger and current sensor are provided as optional, please refer to the actual situation.

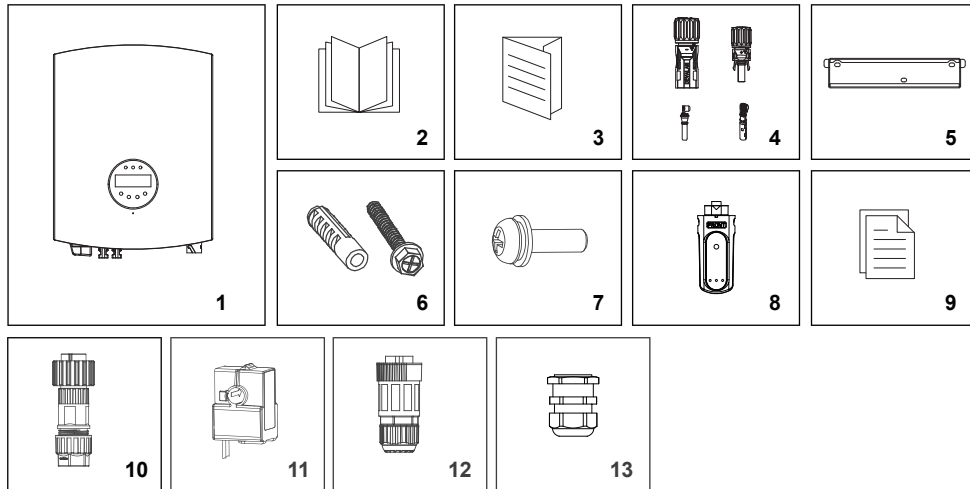

This picture is for reference only. Please refer to the actual situation.

No.	Description	Model	Unit	QTY	Remark
1	Inverter		pcs	1	
2	User manual		pcs	1	
3	Quick installation manual		pcs	1	
4	PV terminals (+, -)		set	2	black
5	Wall-mounting bracket		pcs	1	
6	Self tapping screws+bolt expansion	ST5.5×50+M10×45	pcs	3	
7	Combination screws	M4×12	pcs	2	
8	Datalogger		pcs	1	optional
9	Inspection report		pcs	1	
10	AC wiring terminal		pcs	1	black
11	Current transformer		pcs	1	optional
12	CT connector (s)		pcs	1	optional
13	DRM connector		pcs	1	optional

* The number of PV terminals allocated corresponds to the number of specific inverter terminals.

1.3 Storage

If the inverter is not put into use immediately, please store it according to the following requirements:

- Make sure that the outer packing box is not removed.
- Make sure that the storage temperature is always - 40 °C~+70 °C and the storage relative humidity is always 0~100% without condensation.
- Make sure the inverter stacking height and direction are placed according to the label on the packing box.
- Make sure there is no risk of toppling the inverter after stacking.
- Regular inspection is required during storage. If the package is damaged due to insect and rat bite, the packaging materials shall be replaced in time.
- The inverter shall be put into use after being stored for a long time and inspected and confirmed by professionals.

2 SAFETY PRECAUTIONS

The safety precautions contained in this document must always be observed when operating the equipment.



Watch out:

The inverter has been designed and tested in strict accordance with safety regulations, but as electrical equipment, the relevant safety instructions must be observed before any operation on the equipment. Improper operation may lead to serious injury or property damage.

2.1 General safety



Watch out:

- Due to product version upgrading or other reasons, the document content will be updated from time to time. If there is no special agreement, the document content cannot replace the safety precautions in the product label. All descriptions in this document are for guidance only.
- Please read this document carefully for products and precautions before installing the equipment.
- Professional and qualified electrical technicians who shall be familiar with the relevant standards and safety specifications of the project site must carry out all equipment operations.
- Insulation tools and personal protective equipment shall be used to ensure personal safety during inverter operation. Electrostatic gloves, wrist strap and antistatic clothing shall be worn when contacting with electronic devices to protect the inverter from electrostatic damage.
- Equipment damage or personal injury caused by inverter not installed, used or configured in accordance with the requirements of this document or corresponding user manual is not within the responsibility scope of equipment manufacturer.

2.2 PV string safety



Danger:

- Please use the DC wiring terminals provided with the box to connect the inverter DC cable. If other types of DC wiring terminals are used, serious consequences may be caused, and the equipment damage caused thereby is not within the scope of the equipment manufacturer.
- The solar array (solar panel) will have DC high voltage.



Warning:

- PV modules used with inverters must have IEC 61730 class A rating or other equivalent standard class.
- Make sure good grounding of component frame and support system.
- Do not ground the PV array positive (+) or negative (-) as this may cause serious damage to the inverter.
- Make sure that the DC cables are firmly connected without looseness after connection.
- Use a multimeter to measure the positive and negative electrodes of the DC cable. Make sure that the positive and negative electrodes are correct, no reverse connection occurs and the voltage is within the allowable range.
- Do not connect the same PV string to multiple inverters, or the inverter may be damaged.
- In order to reduce the risk of fire, the inverter connected circuit requires an overcurrent protection device (OCPD). DC OCPD shall be installed according to local requirements. All PV power supplies and circuit conductors shall have disconnect connections in accordance with NEC Article 690, Part II.

2.3 Inverter safety



Danger:

- Please connect the inverter AC cable with the AC wiring terminals provided with the box. If other types of AC wiring terminals are used, serious consequences may be caused, and the equipment damage caused thereby is not within the scope of the equipment manufacturer.
- Danger of electric shock. There are no serviceable parts inside the machine. Please do not disassemble it. Please obtain service from qualified and recognized service technicians.



Warning:

- Make sure that the voltage and frequency of the grid connection access point meet the inverter grid connection specifications.
- It is recommended to add circuit breaker or fuse and other protective devices at the AC side of the inverter, and the specification of the protective device shall be 1.25 times greater than the maximum AC output current of the inverter.
- The protective ground wire of inverter must be firmly connected to make sure that the impedance between neutral wire and ground wire is less than 10 Ω.
- Copper core cable is recommended for AC output cable.

Identifications on inverter box are as follows:	
<p>Danger of high voltage. There is high voltage when the inverter is operating. When operating the inverter, make sure the inverter is powered off.</p>	<p>Time delay discharge. Wait for 5 minutes after the equipment is powered off until the equipment is fully discharged.</p>
<p>Please read the product manual carefully before operating the equipment.</p>	<p>Potential hazards after equipment operation. Please take protective measures during operation.</p>
<p>There is high temperature on the inverter surface, so do not touch it when the equipment is running, otherwise, it may cause scald.</p>	<p>Connection point of protective earthing wire.</p>
<p>CE symbol</p>	<p>The equipment shall not be treated as domestic garbage. Please treat the equipment according to local laws and regulations or send it back to the equipment manufacturer.</p>

2.4 Personnel requirements



Watch out:

- Personnel responsible for installing and maintaining equipment must first undergo strict training, understand various safety precautions, and master the correct operating methods.
- Only qualified professionals or trained personnel are allowed to install, operate, maintain, or replace equipment or components.

3 INTRODUCTION

3.1 Products introduction

The AUX ASN series single-phase on grid inverter integrates the energy management system in the PV system to control and optimize the energy flow, adapt to the requirements of the smart grid and output the power generated in the PV system to the utility/national grid.

3.2 Outlook introduction

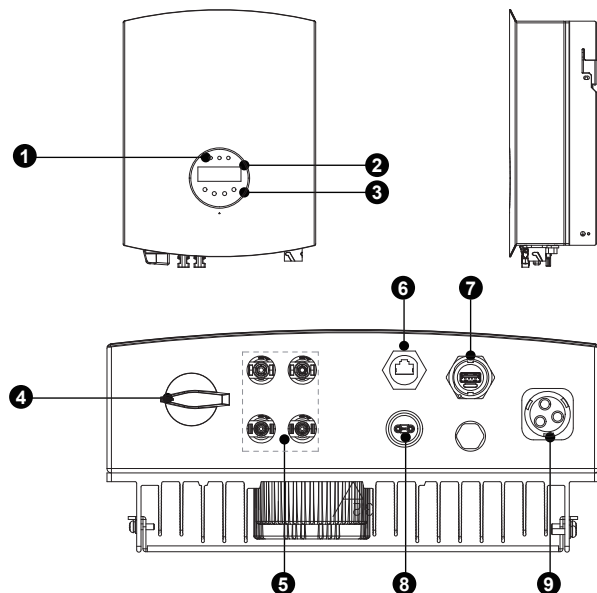

No.	Component	Description
1	LED screen	Indicates the working status of the inverter
2	LCD screen	Display inverter operating parameters
3	Key	Select LCD display page and set parameters
4	DC switch	Control DC input on or off (warning: this switch does not have breaking capacity and is prohibited to operate when the machine is running)
5	PV DC port	Connect PV module with PV wiring connector
6	DRM port	Demand response interface (note: applicable to Australian regulations, optional)
7	Communication module port	Communication module can be connected via RS485, supporting optional communication modules such as bluetooth, Wi-Fi and 4G
8	CT port	External CT current transformer, anti-reflow function (optional)
9	AC interface	Connect AC mains supply

3.3 Dimension

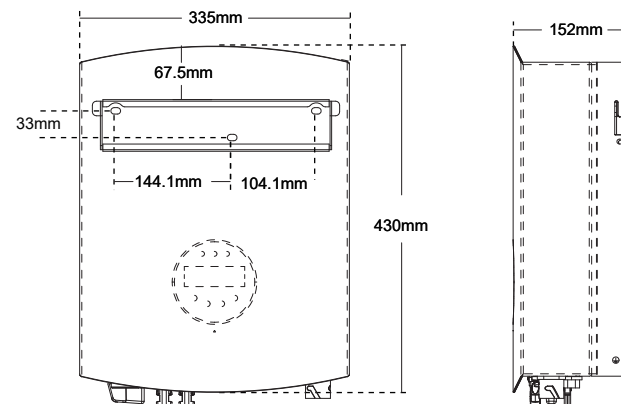

3.4 Display description

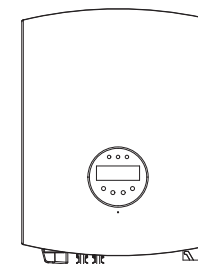

Indicator diagram	Status	Description
LED display light	Red always on	Fault mode
	Yellow flashes	Alert mode
	Green always on	Normal operation
	Green flashes	Standby mode
Key	ESC key	Exit key
	UP key	Scroll up key
	Down key	Scroll down key
	Enter Key	Confirm key
LCD display light	LCD screen	Display the current operating parameters of inverter

3.4.1 LCD work menu

The LCD is located on the front panel of the inverter, which shows the following information:

- Inverter operation status and data.
- Alarm messages and fault indications.

The LCD screen can also be scrolled manually by pressing UP or DOWN. Pressing the ESC or ENTER key returns you to the previous menu or enters the main menu.

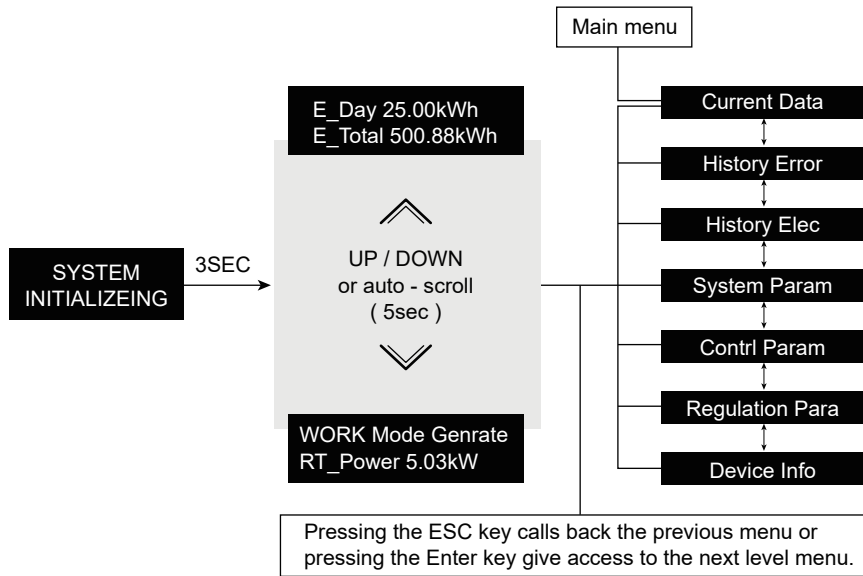

3.4.2 Main menu

There are 7 submenus in the main menu:

- Current Data
- History Error
- History Elec
- System Param
- Control Param
- Regulation Para
- Device Info

3.4.3 Current data

The AUX ASN series single-phase inverter main menu provides access to operating data and information. Select Current Data from the menu to display the information and scroll up or down.

No.	Display	Description
1	1.Mode Generate	Display the current operating mode of inverter.
2	2.GRID VOLT 220.0V	Display grid voltage value
3	3.GRID P 4.98KW	Display the instant output power value
4	4.GRID FREQ 50.00HZ	Display grid frequency value
5	5.E_DAY 25.78KWH	Total Elec on that day
6	6.E_TOTAL 8458.57 kWh	Total Elec
7	7.PV INFO 2	Display PV quantity
	1.PV1 INFO 260.0V 10.70A	Display PV1 voltage and current information
	2.PV2 INFO 260.0V 10.70A	Display PV2 voltage and current information
8	8.Load Power 5.00kW	Display inverter load power

3.4.4 History error

2022-03-04 19:33:39 10. IsolationAlarm	LCD display shows the latest 30 alarm messages. Press UP/DOWN to manually scroll through the screen. Press ESC to return to the previous menu.
---	--

3.4.5 History elec

Select the date of daily generation

2022-03-05 23.51kWh	1. His Daily Elec This function is used to view the generated energy on the selected date. Press UP/DOWN to change the date.
------------------------	--

Select the month of monthly generation

2022-03 223.51kWh	2. His Month Elec This function is used to view the energy production for the selected month. Press UP/DOWN to change the month.
----------------------	--

Select the year of annual energy production

2022 1323.51kWh	3. His Year Elec This function is used to view the energy production for the selected year. Press UP/DOWN to change the year.
--------------------	---

3.4.6 System param

3.4.6.1 Set address

This function is used to set the address when multiple inverters are connected to a single monitor. The address number can be assigned from " 01 " to " 10 ".

1.Comm Addr 1	The default address number of AUX ASN series single-phase inverter is " 01 ". Press UP/DOWN to set the address. Press ENTER to save the settings. Press ESC to cancel the change and return to the previous menu.
------------------	---

3.4.6.2 Selecting regulation

This function is used to select the reference regulation for the grid.

2.Regulation CQC	Press UP/DOWN to select the regulation. (CQC, Brazil, EN_50549, IEC61727_50, IEC61727_60, Wide_Range_50, Wide_Range_60,Spain, Poland).
---------------------	--

	Attention: This function is for technical personnel only. For different countries, grid regulations need to be set differently according to local requirements. If in doubt, consult your AUX technician. The following are user-defined setting ranges. With this function the limits can be changed manually. (CQC,Brazil, EN_50549, IEC61727_50, IEC61727_60, Wide_Range_50, Wide_Range_60, Spain, Poland).
---	--

3.4.6.3 Set language

3.Language English	Press UP/DOWN to set the language. Press ENTER to save the settings. Press ESC to cancel the change and return to the previous menu.
-----------------------	--

3.4.6.4 Set time

This function allows to set time and date. When this function is selected, the LCD displays the following <Time Setup>

4.Time Set 2023/04/24 11:01:03	Set Time	1.Date-Year 2023	Set Year
2.Date-Month 4	Set Month	3.Date-Day 24	Set Day
4.Time-Hour 11	Set Hour	5.Time-Minute 1	Set Minute
6.Time-Second 3	Set Second		

Press UP/DOWN to set the time and date. Press ENTER to save the settings and press ESC to return to the previous menu.

3.4.7 Contrl param

	Attention: Only fully qualified and approved technicians shall enter the area. Password is required to enter the menu " Control Parameters ". Select " Control Parameters " on the main menu. The screen will require the following password:
---	---

Password 1020	Enter password, The default password is " 1020 ". Press DOWN to move the cursor and press UP to select the number. 1. Remote control 2. Restore factory 3. Clear His.error
------------------	---

3.4.7.1 Remote control

This function is used to start or stop AUX single-phase inverter power generation.

Remote control Power on	Press UP/DOWN to manually scroll the screen, press ENTER to save the settings, and press ESC to return to the previous menu.
----------------------------	--

3.4.7.2 Clear his.error

This function is used to clear the fault record.

His Elec Clear? Cancel affirm

Press ENTER to save the settings. Press ESC to return to the previous menu.

3.4.7.3 Restore factory

Restore factory settings to set special settings for all items to default values. The screen displays as follows:

Restore? Cancel affirm

Press ENTER to save the settings. Press ESC to return to the previous menu.

3.4.8 Regulation para



Attention:

Only fully qualified and approved technicians shall enter the area. Password required to enter the menu " Regulation Para ". Select " Regulation Parameter Para " to enter the main menu. The password required on the screen is:

Password 1020

Enter password, The default password is " 1020 ". Press DOWN to move the cursor and UP to select numbers. When the correct password is entered, the main menu displays an interface to access the following information:

No.	Display	Description
1	1.Grid Over Volt _1 110%	Display the primary over voltage protection value of power grid
2	2.Grid Over Volt _T1 1000ms	Display the primary over voltage protection time of power grid
3	3.Grid Over Volt _2 135%	Display the secondary over voltage protection value of power grid
4	4.Grid Over Volt _T2 40ms	Display the secondary over voltage protection time of power grid
5	5.Grid Over Volt _3 135%	Display the three-level over voltage protection value of power grid
6	6.Grid Over Volt _T3 40ms	Display the three-level over voltage protection time of power grid
7	7.Grid Under Volt _1 85%	Display the primary under voltage protection value of power grid
8	8.Grid Under Volt _T1 1000ms	Display the primary under voltage protection time of power grid
9	9.Grid Under Volt _2 50%	Display the secondary under voltage protection value of power grid
10	10.Grid Under Volt _T2 80ms	Display the secondary under voltage protection time of power grid
11	11.Grid Under Volt _3 20%	Display the three-level under voltage protection value of power grid
12	12.Grid Under Volt _T3 40ms	Display the three-level under voltage protection time of power grid
13	13.Grid Over Freq _1 50.50HZ	Display the primary over-frequency protection value of power grid

No.	Display	Description
14	14.Grid Over Freq_T1 180ms	Display the primary over-frequency protection time of power grid
15	15.Grid Over Freq_2 55.00HZ	Display the secondary over-frequency protection value of power grid
16	16.Grid Over Freq_T2 140ms	Display the secondary over-frequency protection time of power grid
17	17.Grid Over Freq_3 55.00HZ	Display the three-level over-frequency protection value of power grid
18	18.Grid Over Freq_T3 140ms	Display the three-level over-frequency protection time of power grid
19	19.Grid Under Freq_1 47.50HZ	Display the primary under-frequency protection value of power grid
20	20.Grid Under Freq_T1 180ms	Display the primary under-frequency protection time of power grid
21	21.Grid Under Freq_2 45.00HZ	Display the secondary under-frequency protection value of power grid
22	22.Grid Under Freq_T2 140ms	Display the secondary under-frequency protection time of power grid
23	23.Grid Under Freq_3 45.00HZ	Display the three-level under-frequency protection value of power grid
24	24.Grid Under Freq_T3 20ms	Display the three-level under-frequency protection time of power grid
25	25.Restart Time 60s	Display start time
26	26.Reconnected Time 60s	Display reconnection time

Press UP/DOWN to manually scroll the screen. Press Enter to enter the parameter modification interface, press DOWN to move the cursor, press UP to select numbers, press ENTER to save the settings, press ESC to cancel the changes and return to the previous menu.

3.4.9 Device info

3.4.9.1 Software version

1. Software Version ARM:A1259 DSP:A1012	This screen displays the inverter software version number.
--	--

3.4.9.2 Rated power

2. Rated Power 5 kW	The screen displays the inverter's rated power.
------------------------	---

3.4.9.3 SN number

3. SN Number ASN-5SL2304260018	The screen displays the SN serial number of the inverter.
-----------------------------------	---

4 APPLICATION

4.1 Application scenario



Warning:

- PV systems are not suitable for connecting devices that rely on stable power supply, such as life-sustaining medical equipment. Please ensure that the power outage of the system does not cause personal injury.
- When the inverter is protected for a single time, the inverter can be automatically restarted. If it happens multiple times, the inverter will stop waiting and can be restarted immediately via the App.

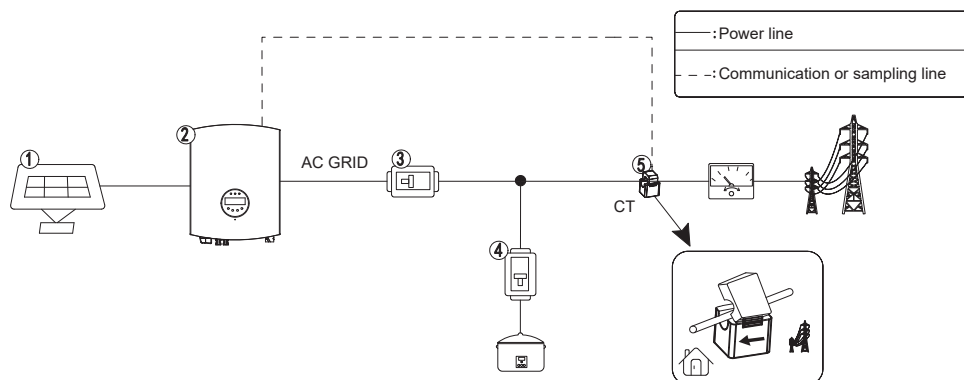

No.	Component	Description
1	PV string assembly	PV string consists of PV modules connected in series
2	Inverter	ASN series on grid inverter
3	AC circuit breaker	Used for inverter and load protection and for interrupting AC supply during maintenance
4	AC circuit breaker	For protecting household loads
5	CT current transformer	Used for anti-reflow function

AC circuit breaker

Model	Voltage(Vac)	Current(A)
ASN-3.6SL	≥230	25
ASN-(4~5)SL	≥230	32
ASN-3.6SL-PLUS	≥230	25
ASN-(4~6)SL-PLUS	≥230	32

4.2 Application mode

4.2.1 Self-use



Watch out:

It is applicable to regions with high electricity cost, low electricity sales revenue and stable power grid.

PV energy sufficient:

PV energy shall be preferentially supplied to the load, and the remaining energy shall be sold. As shown in the figure below, ① and ② represent energy priority.

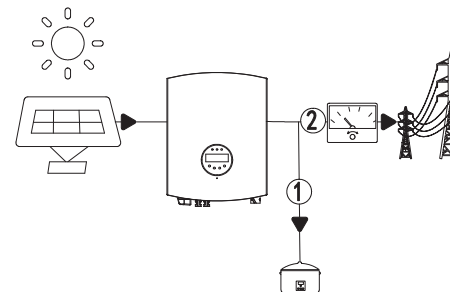

4.2.2 Full grid connection

If no load is required, all energy of the inverter can be supplied to the utility/national grid to realize full grid connection of power generation.

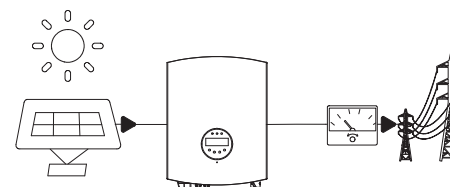

4.3 Function characteristics

4.3.1 Power derating

In order to make the inverter operate safely, the inverter will automatically reduce the output power when the operating environment is not ideal.

The following factors may cause power derating, so please try to avoid them during use.

- Unfavorable environmental conditions such as direct sunlight, high temperatures, etc
- The inverter's output power percentage has been limited by the app or web-end settings
- Variation with grid voltage frequency
- High input voltage
- High input current value

5 INSTALLATION

5.1 Installation requirements

5.1.1 Environmental requirements

- The protection class of inverter is IP66*, which can be installed indoor and outdoor.
- Equipment shall not be installed in flammable, explosive and corrosive environment.
- The installation position shall be kept away from the accessible range of children and the position easy to be touched. High temperatures may be present on the surface when the equipment is in operation to prevent burns.
- The installation position shall avoid the water pipe and cable in the wall to avoid danger during punching.
- The inverter shall avoid salt fog areas and installation environments such as sunshine, rain and snow. It is recommended to install the inverter in a sheltered installation position. If necessary, a sunshade can be erected.
- When installing the inverter, certain space shall be reserved around the inverter to ensure sufficient installation and heat dissipation space.
- Under the installation scenario of multiple inverters, when the space is sufficient, the installation mode of "straight line" is recommended. When the space is insufficient, it is recommended to install the product in a zig-zag manner. It is not recommended to install multiple inverters by overlapping.
- The installation height of the equipment shall be convenient for operation and maintenance, ensure that the equipment indicator lights, all labels are easy to see, and the terminal blocks are easy to operate.
- The inverter is installed at an altitude lower than the maximum working altitude of 4000m.
- Keep away from strong magnetic field environment to avoid electromagnetic interference. If there is a radio station near the installation location or wireless communication equipment below 30MHz, please install the equipment according to the following requirements:

Ferrite core with multi-circle winding or low-pass EMI filter at inverter DC input or AC output.

The distance between inverter and wireless electromagnetic interference equipment exceeds 30m.

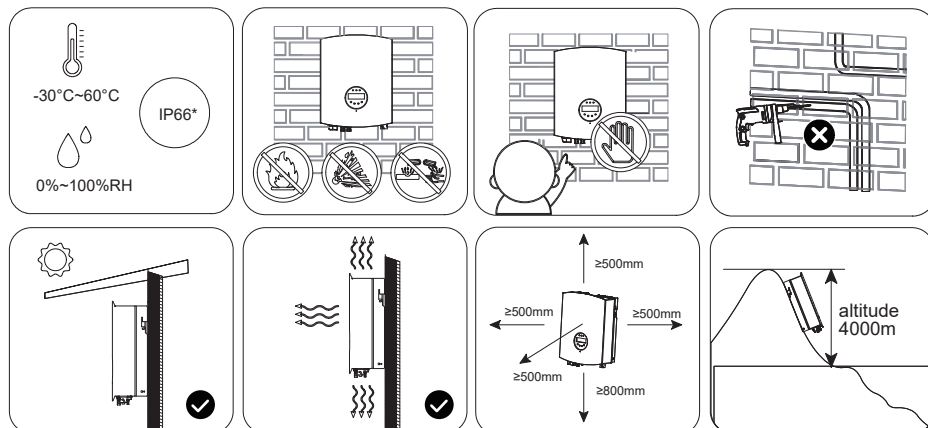

*: ASN-(3.6~5)SL:IP65 / ASN-(3.6~6)SL-PLUS:IP66

5.1.2 Carrier requirements

- Installation carriers must not be flammable and must be fire resistant.
- Please make sure that the mounting carrier is solid and reliable and can bear the weight of inverter.
- The equipment will vibrate during operation, so do not install it on the carrier with poor sound insulation, so as to avoid disturbance to residents in the living area caused by the noise generated by the equipment during operation.

5.1.3 Installation angle requirements

- Recommended inverter installation angle: vertical or pitching $\leq 15^\circ$.
- Do not invert, tilt forward, tilt backward beyond the angle and install the inverter horizontally.

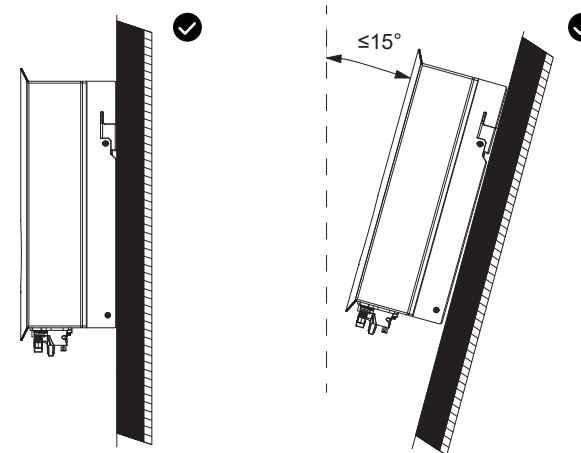

5.1.4 Installation tool requirements

The following installation tools are recommended for installation. Other auxiliary tools can be used on site if necessary.



5.2 Installation of inverter

5.2.1 Handling inverter



Watch out:

- Transportation, turnover, installation and other operations must meet the requirements of national and regional laws and regulations and relevant standards.
- Please equip corresponding personnel according to the weight of the equipment to prevent the equipment from exceeding the weight range that can be handled by human body and damaging personnel.
- Wear safety gloves to avoid injury.
- Please make sure that the equipment is balanced during handling to avoid dropping.

5.2.2 Installation of inverter



Watch out:

- When drilling holes, make sure that the drilling position is kept away from water pipes, cables, etc. in the wall to avoid danger.
- Wear goggles and dust mask when punching to avoid dust inhalation into respiratory tract or into eyes.
- Make sure that the inverter is securely installed to prevent injuries from falling.

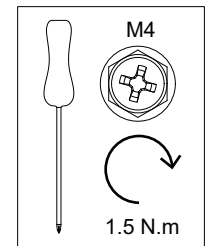
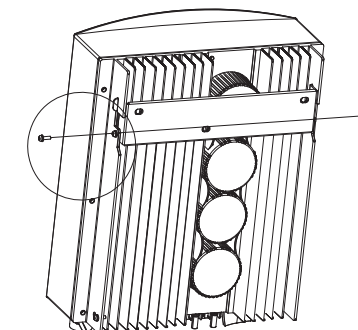
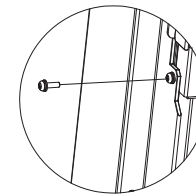
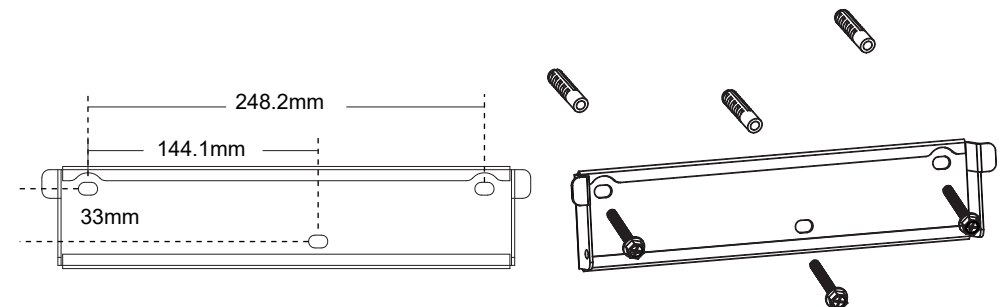

5.3 Electrical connection

5.3.1 Safety precautions



Danger:

- Specifications of all operation, cables and components used in electrical connection shall comply with local laws and regulations.
- Before electrical connection, please disconnect the DC switch and AC output switch of inverter to make sure that the equipment is powered off. It is strictly forbidden to operate with electricity, otherwise, electric shock and other hazards may occur.
- Cables of the same type shall be bound together and arranged separately from cables of different types. It is forbidden to wind or cross cables.
- If the cable bears too much tension, it may lead to poor wiring. When wiring, please reserve a certain length of the cable before connecting to the inverter wiring port.
- When crimping the connecting terminal, please make sure that the conductor part of the cable is fully contacted with the connecting terminal, and do not crimp the cable insulation skin together with the connecting terminal, otherwise, the equipment may be unable to operate, or the inverter terminal block may be damaged due to heating due to unreliable connection after operation.



Watch out:

- When making electrical connection, please wear safety shoes, protective gloves, insulating gloves and other personal protective equipment as required.
- Only professionals are allowed to carry out operations related to electrical connection.

5.3.2 Connecting protective earth wire



Warning:

- The protective grounding of the crate shell cannot replace the protective grounding wire of the AC output port. When wiring, ensure that the protective grounding wires at the two places are reliably connected.
- In case of multiple inverters, make sure that the protective earthing point of all inverter crate enclosures is equipotentially connected.
- To improve the corrosion resistance of the terminal, it is recommended to apply silicone or paint on the external of the grounding terminal for protection after the connection and installation of the protective ground wire.
- Please prepare the protective ground wire, and the recommended specification:
Type: Outdoor single-core copper wire
Conductor sectional area: 4-6mm² (12 - 10AWG)

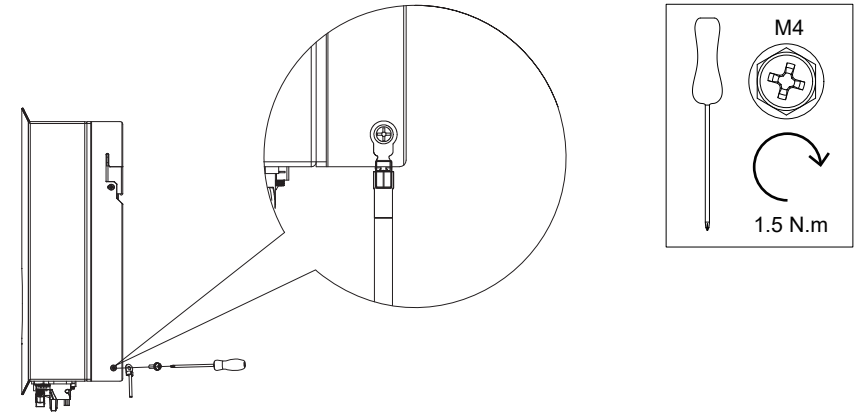
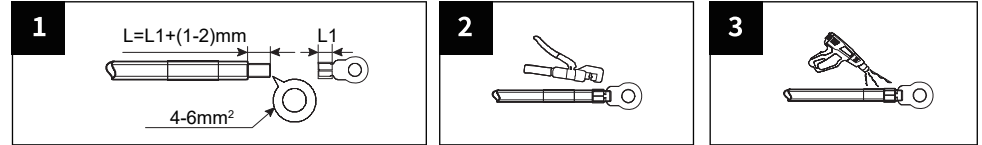

5.3.3 Connect PV input cable

Danger:

- Do not connect the same PV string to multiple inverters, otherwise the inverter may be damaged.
- Please make sure that the maximum short circuit current and maximum input voltage of each MPPT are within the allowable range of the inverter.
- Please make sure that the positive electrode of the PV string is connected to the PV port + of the inverter, and the negative electrode of the PV string is connected to the PV port - of the inverter.
- Please prepare your own PV input cable. Recommended specification:
 Type: Outdoor PV multi-core copper wire
 conductor cross-section: 4-6mm² (12 - 10AWG)
 Outer diameter of conductor insulation layer: φ3~7mm



Warning:

- PV string output does not support grounding. Before connecting PV string to inverter, please make sure that the minimum insulation resistance to ground of PV string meets the minimum insulation impedance requirements ($R = \text{maximum input voltage} / 30\text{mA}$).
- Make sure that the DC cables are firmly connected without looseness after connection. Use a multimeter to measure the positive and negative electrodes of the DC cable and ensure that the positive and negative electrodes are correct without reverse connection, and the voltage is within the allowable range.

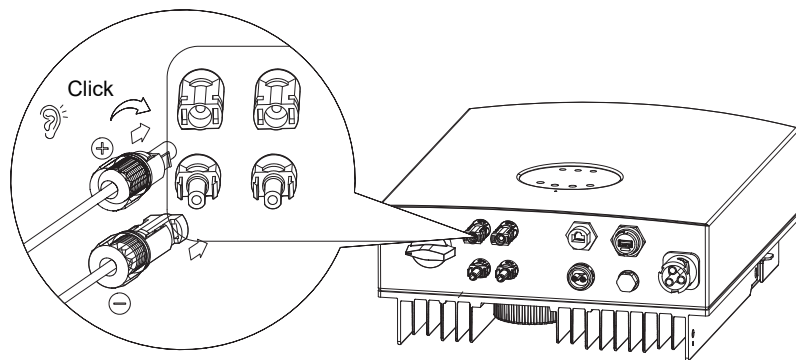

1

Limit clips cannot be curled

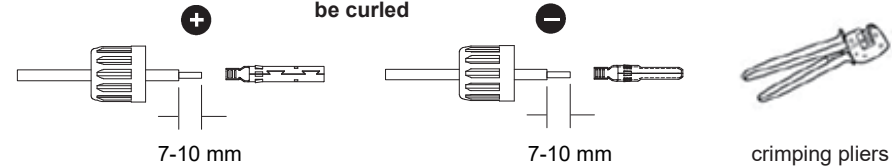

2

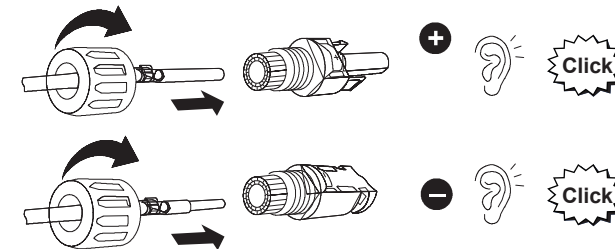

3

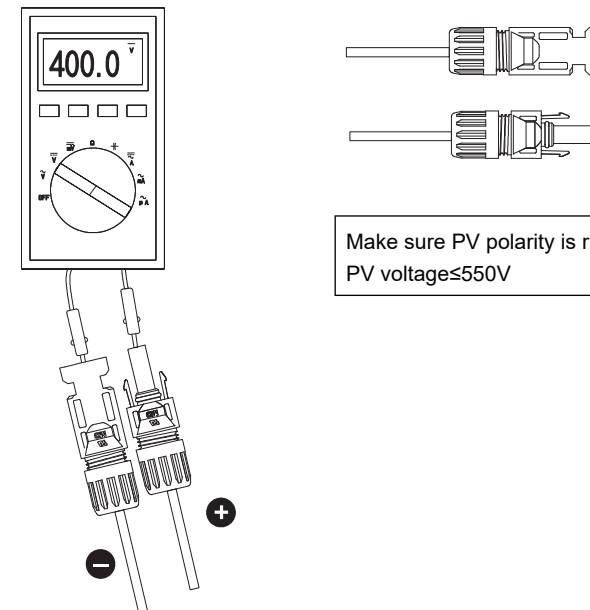

5.3.4 Connecting AC cable

Danger:

- In order to ensure that the inverter and the grid can be safely disconnected from the grid in case of abnormal conditions, please connect the AC switch on the AC side of the inverter. Multiple inverters cannot be connected to one AC switch at the same time. Please select proper AC switch according to local regulations.
- Please prepare your own PV input cable. Recommended specification:
- Type: Outdoor AC single-core copper wire

Model	Wire gauge	Conductor cross-section
ASN-3.6SL	12AWG	3.33mm ²
ASN-(4~5)SL	10AWG	5.26mm ²
ASN-3.6SL-PLUS	12AWG	3.33mm ²
ASN-(4~6)SL-PLUS	10AWG	5.26mm ²

- If multi-core copper wire is selected, supporting crimping terminal shall be used for assembly. It is forbidden to directly press multi-core copper wire into the connector.



Warning:

- Residual current monitoring unit (RCMU) is integrated in the inverter. When the inverter detects leakage current greater than the allowable value, it will quickly disconnect from the grid.
- During wiring, the AC cable is completely matched with "L", "N" and grounding port of AC terminal. If the cable is connected improperly, the equipment will be damaged.
- Make sure that the core is completely inserted into the terminal hole without exposure.
- Ensure that the cables are firmly connected, otherwise the terminal may be overheated and the equipment may be damaged when the equipment is operating.

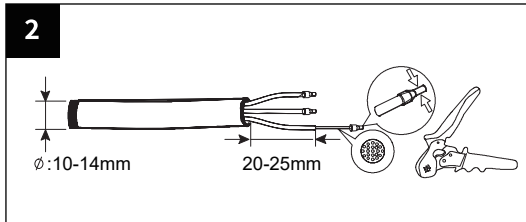
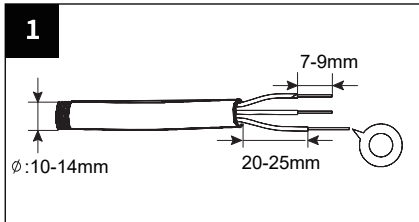
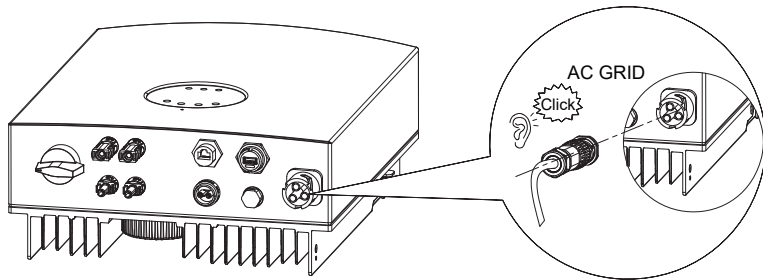

Note:

- Single core wire, no terminal pressing operation required.
- For multi-core wires, cold-pressed terminal crimping pliers shall be used for crimping terminals.

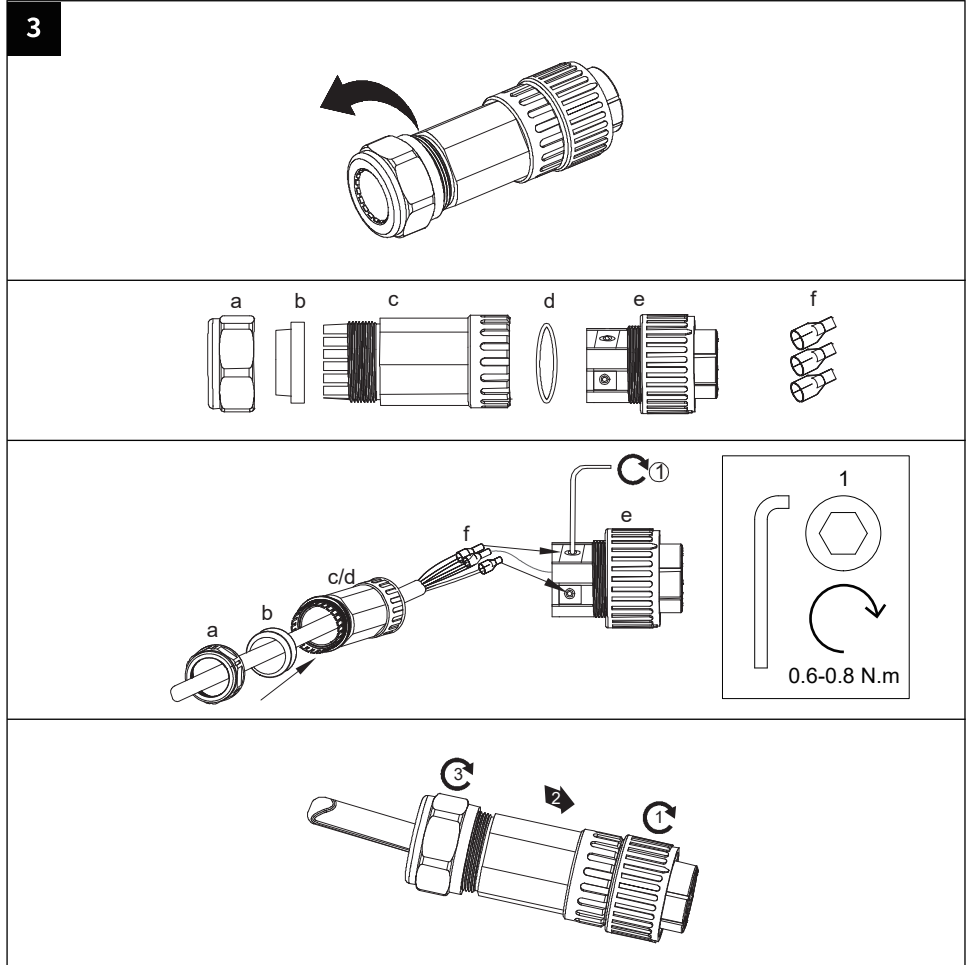

5.3.5 CT anti-reflow (optional)



Watch out:

- When connecting signal cables, the cable route shall avoid interference sources, power cables, etc. to avoid affecting signal reception.
- CT is shipped with inverter and relevant parameters have been preset before delivery. Please do not modify relevant parameters of CT.
- Please connect CT according to the current direction, and the inverter cannot work properly if it is in reverse direction.
- The length of CT cable provided with inverter is 5m. Please install CT properly according to the actual situation.
- Use CT current sensor to control the inverter's power generation to the grid. Install the current sensor on the L-wire of the power grid, ensure the direction of the current sensor from the L-wire of the power grid to the home, insert the terminal into the CT port of the inverter and tighten the terminal. Install the black wire on the "-" mark of the terminal and the black and white wire on the "+" mark of the terminal.

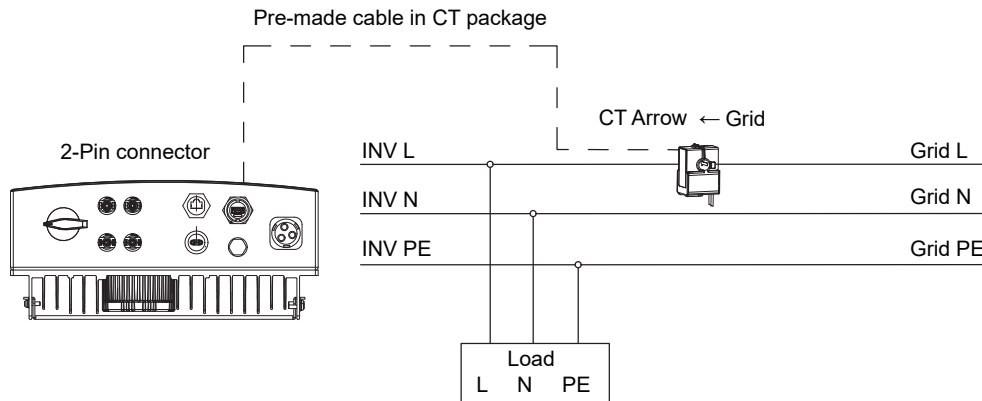
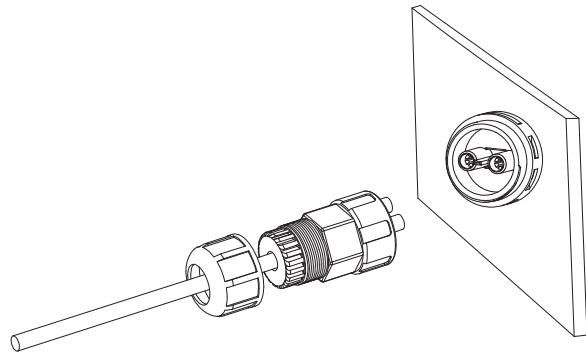

5.3.6 DRM control (optional)



Watch out:

- When connecting communication cables, please ensure that the definition of the wiring port matches the device perfectly, and the cable routing should avoid interference sources, power cables, etc. to avoid affecting signal reception.
- Please provide your own RJ45 registered jack. It is recommended to use T568B standard super five and above standard network cables.
- The communication cable from DRM to inverter can be connected to the standard RJ45 registered jack, and the ports are defined as follows:

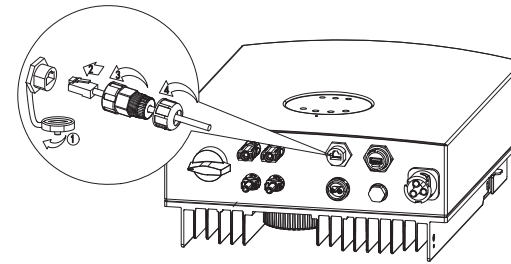

1 2 3 4 5 6 7 8

Pin	Function	Pin	Function
1	DRM 1/5	5	REF
2	DRM 2/6	6	Com/DRM0
3	DRM 3/7	7	V+
4	DRM 4/8	8	V-

5.3.7 Datalogger connection (optional)



Watch out:

Detailed introduction of communication module can be obtained from the official website.

1. Open the COM port cover plate, assemble the datalogger and USB port together as shown in the figure, and tighten the datalogger.
2. The datalogger can support Wifi, 4G or LAN communication. Refer to the datalogger installation guide for detailed operation.

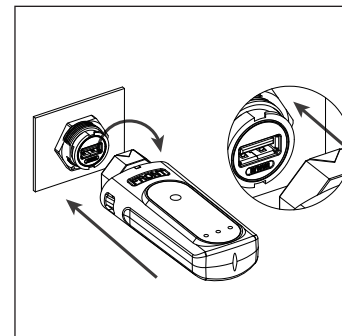

fig. 1

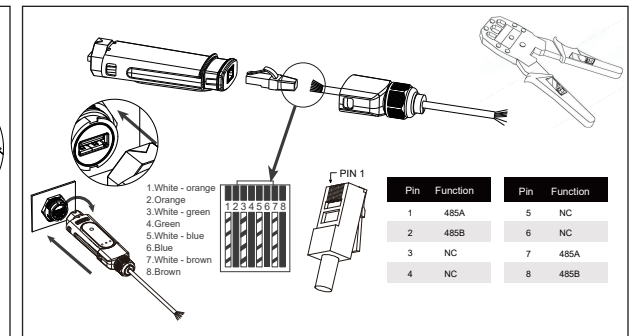

fig. 2

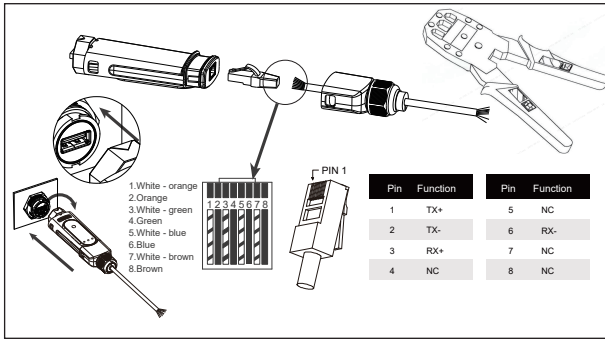

fig. 3

6 EQUIPMENT COMMISSIONING AND MAINTENANCE

6.1 Check before power-on

Items	Checking items	Standard
1	Installation of inverter	The inverter shall be installed correctly, firmly and reliably
2	Cable arrangement	Cables shall be reasonably arranged and well protected, without damage
3	Datalogger	The datalogger shall be installed correctly, firmly and reliably
4	Identifying	The safety signs and warning labels on the inverter are not blocked or damaged
5	Switch	" DC SWITCH " and all switches connected to the inverter are " OFF "
6	Cable connection	The AC output cable, DC input cable and grounding wire are connected correctly, firmly and reliably
7	Unused terminals and interfaces	Unused terminals and interfaces are protected with waterproof covers
8	Circuit breaker	Reasonable selection of AC and DC circuit breakers
9	Environmental requirements	Reasonable installation space, clean and tidy environment, no construction remains

6.2 Power on the equipment

- Step 1: Please use the multimeter to measure the grid voltage at the switch between the grid input and the inverter, to make sure that the voltage is in the allowable range of the inverter.
- Step 2: Close the AC switch between inverter and utility/national grid.
- Step 3: Set " DC SWITCH " on the inverter to " ON ".
- Step 4: Observe the inverter LED indicator and check the inverter operation status.

6.3 Set inverter parameters via APP



Watch out:

To ensure that the inverter works properly, please use the application program to complete the inverter parameter setting.

Scan the QR code below to download the application or log in following website to download this application :

<https://www.auxsolcloud.com>



Watch out:

Please also obtain the operating instructions of the communication rod from the official website, to set the contents more consistent with the application scenario.

6.4 Power off the equipment



Danger:

- When operating and maintaining the inverter, please turn off the inverter for treatment. Live operation of the equipment may cause damage to the inverter or electric shock.
- After the inverter is powered off, it will take a certain amount of time for internal components to discharge. Please wait until the equipment is fully discharged according to the required label time requirements.

- Step 1: Disconnect the AC switch between the inverter and the utility/national grid.
- Step 2: At the AC switch between the inverter and the utility/national grid, measure the voltage on the power grid side with a multi-meter to confirm that the power has been cut off.
- Step 3: Observe the inverter LED indicator, check the inverter operation status, and confirm to enter standby.
- Step 4: Set " DC SWITCH " on inverter to " OFF ".

6.5 Equipment removal



Danger:

- Make sure inverter is power off.
- Wear personal protective equipment when operating the inverter.

Step 1: Successively remove all electrical connections of inverter, including DC cable, AC cable, communication cable, communication module and protective earth wire.

Step 2: Remove the inverter from the back cladding.

Step 3: Remove the back cladding.

Step 4: Properly save the inverter and ensure that the storage conditions meet the requirements if the subsequent inverter is still put into use.

6.6 Equipment scrapping

If the inverter cannot be used anymore and needs to be scrapped, please dispose according to the electrical waste disposal requirements of the inverter country/region.

The inverter shall not be treated as household garbage.

6.7 Trouble shooting

Please troubleshoot according to the following methods. If the troubleshooting methods cannot help you, please contact the after-sales service center.

When contacting the after-sales service center, please collect the following information for quick solution.

1. Inverter information, such as serial number, software version, equipment installation time, fault occurrence time, fault occurrence frequency, etc.
2. Equipment installation environment, such as weather conditions, whether components are sheltered and whether there is shadow, etc. It is recommended to provide photos, videos and other documents to assist in analyzing problems.
3. Utility/National grid condition.

If there is only indicator mode for inverter, fault information can be viewed through back platform/APP mode.

Defect codes	Defect name	Fault cause	Solutions
0101	BUS software overvoltage	<ol style="list-style-type: none"> 1. Abnormal grid or load fluctuation 2. Weak light or abnormal light changes. 3. The configuration of the photovoltaic array is wrong, and the number of photovoltaic panels connected in series is too large. 4. Poor insulation of photovoltaic to ground. 	<ol style="list-style-type: none"> 1. If it happens by chance, it may be caused by abnormal power grid, load or light for a short time. After the self-check is normal, the inverter will return to normal operation without manual intervention. 2. Check the series configuration of the corresponding photovoltaic array string to ensure that the open circuit voltage of the string is not higher than the maximum working voltage of the inverter. 3. Check the impedance of the photovoltaic string to the protection ground. If there is a short circuit, please rectify the short circuit point. 4. Restart the inverter after disconnecting the off-grid load. If The restart is normal, you need to increase the battery or reduce the off-grid load (hybrid inverter).
0102	BUS undervoltage		
0104	BUS hardware overvoltage		
0301	R-phase inverter soft start timeout	<ol style="list-style-type: none"> 1. Abnormal fluctuation of power grid. 2. Inverter sampling fault. 3. Wiring failure. 	<ol style="list-style-type: none"> 1. If it happens by accident, it may be caused by abnormal power grid or load for a short time. After the self-check is normal, the inverter will return to normal operation without manual intervention. 2. Disconnect the AC circuit breaker, battery circuit breaker and photovoltaic input switch in turn, and close the battery circuit breaker, AC circuit breaker and photovoltaic input switch in turn after 10 minutes to check whether the fault is still there. 3. Please check whether the photovoltaic, AC and battery cables are correctly connected according to the wiring requirements of the manual.

Defect codes	Defect name	Fault cause	Solutions
0601	R-phase inverter software overcurrent	1. Abnormal grid or load fluctuation. 2. Inverter sampling fault.	1. If it happens by accident, it may be caused by abnormal power grid or load for a short time. After the self-check is normal, the inverter will return to normal operation without manual intervention. 2. If it occurs frequently, check whether the voltage frequency of the power grid is stable. If the power grid fluctuates greatly, enable the weak power grid mode and restart the inverter. 3. If it appears during the first installation, please check whether the power grid is connected to the off-grid output interface (hybrid inverter) by mistake according to the wiring requirements of the manual. 4. Restart the inverter after disconnecting the off-grid load. If The restart is normal, you need to increase the battery or reduce the off-grid load (hybrid inverter).
0701	R-phase inverter hardware overcurrent		
0704	Bridge arm overcurrent		
0801	R-phase inverter high voltage		
1501	Control panel temperature too high	1. The installation position of the inverter is not ventilated. 2. The ambient temperature is too high. 3. The fan works abnormally.	1. Check whether the ventilation of the inverter installation position is good and whether the ambient temperature exceeds the maximum allowable ambient temperature range. 2. If there is no ventilation or the ambient temperature is too high, please improve its ventilation and heat dissipation. 3. Check whether the fan is working normally, whether the air duct is blocked or blocked by dust.
1504	Temperature of Inverter Module is too high		
1505	Control board NTC not connected		

Defect codes	Defect name	Fault cause	Solutions
1801	PV1 overvoltage	The configuration of the photovoltaic array is wrong, and the number of photovoltaic panels connected in series is too large.	Check the series configuration of the corresponding photovoltaic array string to ensure that the open circuit voltage of the string is not higher than the maximum operating voltage of the inverter.
1802	PV2 overvoltage		
1901	PV input software overcurrent	1. Unreasonable component configuration. 2. Abnormal illumination changes.	1. Series configuration of photovoltaic array strings to ensure that the current specifications of the strings are within the specifications of the inverter. 2. If it happens by accident, it may be caused by abnormal light for a short time. After the self-check is normal, the inverter will return to normal operation without manual intervention.
2001	PV input hardware overcurrent		
2101	PV input arc fault	1. The DC string connection terminal is not firmly connected. 2. The DC wiring is damaged.	Please check whether the component cables are properly connected according to the wiring requirements in the manual.
2201	PV1 reverse connection	The positive and negative poles of the DC series connection are reversed.	Turn off the AC circuit breaker, battery circuit breaker and photovoltaic input switch in turn. After the inverter is turned off, adjust the DC ancestral positive and negative wiring, turn off the battery circuit breaker, AC circuit breaker and photovoltaic input switch in turn to check whether the fault is still the same.
2202	PV2 reverse connection		
2301	PV1 short circuit	Short circuit in DC string.	Disconnect the AC circuit breaker, battery circuit breaker and photovoltaic input switch in turn, and then close the battery circuit breaker, AC circuit breaker and photovoltaic input switch in turn after 10 minutes to check whether the fault persists.
2302	PV2 short circuit		

Defect codes	Defect name	Fault cause	Solutions
2401	Internal fan	1. Abnormal power supply of fan. 2. Mechanical failure (locked rotor). 3. The fan is aged and damaged.	Check whether the fan is working properly, whether the air duct is blocked or blocked by dust.
2402	External fan		
2501	First-order overvoltage (lowest voltage)	The grid voltage exceeds or falls below the allowable range.	1. If it happens accidentally, it may be that the power grid is abnormal for a short time. The inverter will return to normal operation after detecting that the power grid is normal, without manual intervention. 2. If it appears frequently, please check whether the grid voltage is within the allowable range. • If the grid voltage is outside the allowable range, contact your local electricity operator. • If the grid voltage is within the allowable range, the inverter needs to be modified after obtaining the consent of the local power operator Power grid protection point. 3. If it cannot be recovered for a long time, please check whether the AC side circuit breaker and the output cable are connected normally.
2502	Second-order overvoltage		
2503	Third-order overvoltage		
2504	10 minutes overvoltage		
2505	First-order undervoltage		
2506	Second-order undervoltage		
2507	Third-order undervoltage		
2601	First-order overfrequency (lowest frequency)	Grid frequency exceeds or falls below the allowable range.	1. If it happens accidentally, it may be that the power grid is abnormal for a short time. The inverter will return to normal operation after detecting that the power grid is normal, without manual intervention. 2. If it appears frequently, please check whether the grid voltage is within the allowable range. • If the grid frequency is outside the allowable range, contact the local electricity operator.If the grid frequency is within the allowable range, it is necessary to modify the inverter grid protection point after obtaining the consent of the local power operator. 3. If it cannot be recovered for a long time, please check whether the AC side circuit breaker and the output cable are connected normally.
2602	Second order overfrequency		
2603	Third-order overfrequency		
2604	First-order underfrequency		
2605	Second order underfrequency		
2606	Third-order underfrequency		

Defect codes	Defect name	Fault cause	Solutions
2701	Island fault	The grid has been disconnected, and the grid voltage is maintained due to the existence of the load, and the grid connection is stopped according to the safety protection requirements.	Wait for the grid to return to normal after the machine will be connected again.
2901	ISO fault	1. The photovoltaic string is short-circuited to the protection ground. 2. The installation environment of photovoltaic string is relatively humid for a long time and the line insulation to ground is poor.	1. Check the impedance of the photovoltaic string to the protection ground. It is normal that the resistance value is greater than 50kΩ. If the resistance value is less than 50kΩ, please check the short circuit point and rectify it. 2. Check whether the protective earth wire of the inverter is connected correctly.
3001	GFCI sensor fault	The leakage current sensor has abnormal sampling.	Disconnect the AC circuit breaker, battery circuit breaker and photovoltaic input switch in turn, and then close the battery circuit breaker, AC circuit breaker and photovoltaic input switch in turn after 10 minutes to check whether the fault persists.
3002	GFCI failure	1. The photovoltaic string or AC line is short-circuited to the protection ground. 2. Electrical equipment has Leakage Current. 3. The installation environment of the machine is relatively humid for a long time and the insulation of the line to the ground is poor.	1. Confirm whether the insulation of photovoltaic string and AC line is normal. 2. Check whether there is leakage current in the electrical equipment.
3101	Secondary source exception	Power circuit failure.	Disconnect the AC circuit breaker, battery circuit breaker and photovoltaic input switch in turn. After removing the external communication cable, data acquisition rod and other equipment, close the battery circuit breaker, AC circuit breaker and photovoltaic input switch in turn, check if the fault persists.

Defect codes	Defect name	Fault cause	Solutions
3301	Relay fault	1. Abnormal relay (relay short circuit). 2. Control circuit is abnormal. 3. Abnormal AC measurement wiring (virtual connection or short circuit may exist).	1. Please check whether the AC cable is correctly connected according to the wiring requirements of the manual. 2. Disconnect the AC circuit breaker, battery circuit breaker and photovoltaic input switch in turn, and close the battery circuit breaker, AC circuit breaker and photovoltaic input switch in turn after 10 minutes to check whether the fault is still there.
4001	Grid voltage detection is inconsistent	Abnormal control circuit.	Disconnect the AC circuit breaker, battery circuit breaker and photovoltaic input switch in turn, and then close the battery circuit breaker, AC circuit breaker and photovoltaic input switch in turn after 10 minutes to check whether the fault persists.
4002	BUS voltage detection inconsistent		
4003	GFCI detection inconsistent		
4201	DRM shutdown	Respond to scheduled shutdown.	No need to deal with, if you have any questions, please contact the installer.
4202	Command shutdown		
4203	Remote Locking Machine		

6.8 Regular maintenance



Danger:

The machine must be kept power off state during maintenance.



Watch out:

Regular maintenance can maintain the stability of inverter performance.

Content	Method	Cycle
System Cleaning	Check the cooling fin and air inlet/outlet for foreign matter and dust. Especially the fan needs regular maintenance to prevent debris from blocking the fan and affecting the operation of the inverter.	half year
DC switch	Turn on and off the DC switch for 10 times continuously to ensure the normal function of DC switch.	one year
Electrical connection	Check whether the electrical connection is loose, whether the cable appearance is damaged and whether there is copper leakage.	half year
Tightness	Check whether the tightness of the equipment inlet hole meets the requirements. If the gap is too large or not sealed, it shall be re-closed.	one year

7 TECHNICAL PARAMETER

Model	ASN-3.6SL	ASN-4SL	ASN-4.6SL
input DC			
Max.input power	5.4kW	6kW	6.9kW
Max.input voltage		550V	
Rated voltage		380V	
Start-up voltage		80V	
MPPT voltage range		80-520Vdc	
Max.input current		13.5A/13.5A	
Max.short circuit current		20/20A	
MPPT number		2	
Max. input strings number		2	
MPPT Range Full Load	180-500V	200-500V	230-500V
Output AC			
Rated output power	3.6kW	4kW	4.6kW
Max.apparent output power	3.96kVA	4.4kVA	5.06kVA
Max.output power	3.96kW	4.4kW	5.06kW
Rated grid voltage	1/N/PE, 220V/230V/240V		
Rated grid frequency	50Hz/60Hz		
Rated grid output current	15.7A	17.4A	20.0A
Max.output current	16A	19.4A	22.3A
Power factor	1 (0.8 Leading...0.8Lagging)		
THDi	<3%		

Model	ASN-5SL
input DC	
Max.input power	7.5kW
Max.input voltage	550V
Rated voltage	380V
Start-up voltage	80V
MPPT voltage range	80-520Vdc
Max.input current	13.5A/13.5A
Max.short circuit current	20/20A
MPPT number	2
Max. input strings number	2
MPPT Range Full Load	250-500V
Output AC	
Rated output power	5kW
Max.apparent output power	5.5kVA
Max.output power	5.5kW
Rated grid voltage	1/N/PE, 220V/230V/240V
Rated grid frequency	50Hz/60Hz
Rated grid output current	21.7A
Max.output current	24.3A
Power factor	1 (0.8 Leading...0.8Lagging)
THDi	<3%

Model	ASN-3.6SL-PLUS	ASN-4SL-PLUS	ASN-4.6SL-PLUS
input DC			
Max.input power	5.4kW	6kW	6.9kW
Max.input voltage		550V	
Rated voltage		380V	
Start-up voltage		80V	
MPPT voltage range		80 - 520Vdc	
Max.input current		16A/16A	
Max.short circuit current		20/20A	
MPPT number		2	
Max. input strings number		2	
MPPT Range Full Load	180-500V	190-500V	200-500V
Output AC			
Rated output power	3.6kW	4kW	4.6kW
Max.apparent output power	3.96kVA	4.4kVA	5.06kVA
Max.output power	3.96kW	4.4kW	5.06kW
Rated grid voltage	1/N/PE, 220V/230V/240V		
Rated grid frequency	50 Hz/60Hz		
Rated grid output current	16.4A	18.2A	20.9A
Max.output current	18A	20A	23A
Power factor	1 (0.8 Leading...0.8Lagging)		
THDi	<3%		

Model	ASN-5SL-PLUS	ASN-6SL-PLUS
input DC		
Max.input power	7.5kW	9kW
Max.input voltage		550V
Rated voltage		380V
Start-up voltage		80V
MPPT voltage range		80 - 520Vdc
Max.input current		16A/16A
Max.short circuit current		20/20A
MPPT number		2
Max. input strings number		2
MPPT Range Full Load	210-500V	230-500V
Output AC		
Rated output power	5kW	6kW
Max.apparent output power	5.5kVA	6kVA
Max.output power	5.5kW	6kW
Rated grid voltage	1/N/PE, 220V/230V/240V	
Rated grid frequency	50 Hz/60Hz	
Rated grid output current	22.7A	27.3A
Max.output current	25A	27.3A
Power factor	1 (0.8 Leading...0.8Lagging)	
THDi	<3%	

Efficiency	
Max. efficiency	ASN-(3.6~5)SL: 97.7% ASN-(3.6~6)SL-PLUS: 97.5%
EU efficiency	97.0%
Protection	
Integrated DC switch	Yes
DC rever-polarity protection	Yes
Anti-islanding protection	Yes
Short circuit Protection	Yes
Output over current protection	Yes
Strings monitoring	Yes
DC Surge protection	Type II
AC Surge protection	Type II
Insulation impedance detection	Yes
Residual leakage current detection	Yes
Temperature protection	Yes
AC Over voltage protection	Yes
DC Over current protection	Yes
Integrated AFCI (DC arc-fault circuit protection)	Optional
Antibackflow	Optional

General Data	
Dimensions (W*H*D)	335 x 430 x 152mm
Weight	ASN-(3.6~5)SL: 10.8kg ASN-(3.6~6)SL-PLUS: 11kg
Self consumption(night)	≤1W
Operating temperature range	ASN-(3.6~5)SL: -25...+60°C ASN-(3.6~6)SL-PLUS: -30...+60°C
Cooling concept	Natural Cooling
Max. operation altitude	4000m (Derating above 3000m)
Relative humidity	0-100%
Protective class	I
Ingress protection	ASN-(3.6~5)SL: IP65 ASN-(3.6~6)SL-PLUS: IP66
Topology structure	Transformerless
Grid connection standard	EN 50549-1, IEC 61727, IEC 62116, IEC 61683, UNE 217001, UNE 217002, NTS-631
Type of DC terminal	MC4 connector
Type of AC terminal	Quick connection plug
Display&Communication	
Display	LCD+LED+Bluetooth+APP
Communication interface	RS485, Optional: WIFI, 4G, LAN

The product may be update in the future. The above parameters are for reference only. Please refer to the real thing.

(此页不打印)

打印说明:

- 1、页面按页码调整为中缝装订，对折后成品页面尺寸：142.5x210mm，成品展开尺寸公差 ± 3 mm;
- 2、封面封底157g 铜版纸打印；
- 3、正文内容80g双胶纸，双面黑白打印；
- 4、图面、字体印刷清晰，无乱码、无偏移、无毛边、不起边、油墨不脱落；
- 5、符合RoHs.