



AUXSOL
WIN A GREEN FUTURE TOGETHER

INSTALLATION OPERATION MANUAL

ASN series

ASN-(50~80)TL-G2

ASN-(30~40)TL-LV-G2

AUXSOL
WIN A GREEN FUTURE TOGETHER

Ningbo AUX Solar Technology Co., Ltd.

No.17 Fenglin Road, Cicheng Town,
Jiangbei District, Ningbo City, Zhejiang Province, China

✉ info@auxsol.com

🌐 www.auxsol.com

☎ +86 0574-8765 2201

Ningbo AUX Solar Technology Co., Ltd.



CONTENT

PREFACE

Summary	1
Applicable products	1
Applicable staff	1
Symbol definition	1

1 OPEN THE CARTON TO CHECK

1.1 Inspection before acceptance	2
1.2 Packing list	2
1.3 Storage	3

2 SAFETY PRECAUTIONS

2.1 General safety	4
2.2 PV string safety	4
2.3 Inverter safety	5
2.4 Personnel requirements	5

3 INTRODUCTION

3.1 Products introduction	6
3.2 Outlook introduction	6
3.3 Dimension	7
3.4 Display description	7

PREFACE

Summary

This document mainly introduces the installation, electrical connection, adjustment, maintenance and troubleshooting methods of ASN series three phase on grid solar inverter. Before installing and using the inverter, please read this manual carefully to understand the safety information and get familiar with the functions and characteristics of the inverter. The document may be updated from time to time. Please obtain the latest version of the information and other product information from the official website.

Applicable products

This document is applicable to the following ASN series three phase on grid inverter:

ASN-(50~80)TL-G2

ASN-(30~40)TL-LV-G2

Applicable staff

It is only applicable to professionals who are familiar with local regulations and standards and electrical system, have received professional training and are familiar with the relevant knowledge of the product.

Symbol definition

To better use this manual, the following symbols are used to highlight important information. Please read the symbols and instructions carefully.



Danger:

Indicates a highly potential danger that, if not avoided, could result in death or serious injury to personnel.



Warning:

Indicates a moderate potential hazard, which could lead to death or serious injury if not avoided.



Watch out:

Indicates a low level of potential danger that, if not avoided, may result in moderate or mild injury to personnel.



Watch out:

Emphasizing and supplementing the content may also provide tips or tricks for optimizing product usage, which can help you solve a problem or save you time.

4 APPLICATION

- 4.1 Grid form 18
- 4.2 Application scenario 19
- 4.3 Application mode 20
- 4.4 Function characteristics 20

5 INSTALLATION

- 5.1 Installation requirements 21
- 5.2 Installation of inverter 24
- 5.3 Electrical connection 25

6 EQUIPMENT COMMISSIONING AND MAINTENANCE

- 6.1 Check before power-on 34
- 6.2 Power on the equipment 34
- 6.3 Set inverter parameters via APP 35
- 6.4 Power off the equipment 35
- 6.5 Equipment removal 36
- 6.6 Equipment scrapping 36
- 6.7 Trouble shooting 36
- 6.8 Regular maintenance 43

7 TECHNICAL PARAMETER 44

1 OPEN THE CARTON TO CHECK

1.1 Inspection before acceptance

Before signing for the product, please carefully check the following contents:

- Check the outer packaging for any damage, such as deformation, holes, cracks, or other signs that may cause damage to the equipment inside the packaging. If there is any damage, do not open the packaging and contact your dealer.
- Check if the inverter model is correct. If there is any discrepancy, do not open the packaging and contact your dealer.
- Check whether the type and quantity of delivered items are correct, and whether there is any damage to the appearance. If there is any damage, please contact your dealer.

1.2 Packing list



Watch out:

- The number of PV DC input terminals matches the number of inverter DC input terminals.
- The datalogger and electricity meter kit are provided as optional, please refer to the actual situation.
- The reverse connection of DC positive and negative terminal may cause faults in the inverter.
- Manufacturers recommend that customers use AUXSOL built-in DC fuse terminals to prevent this from happening and protect the inverter.

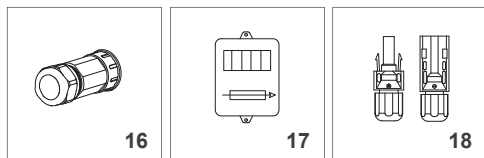
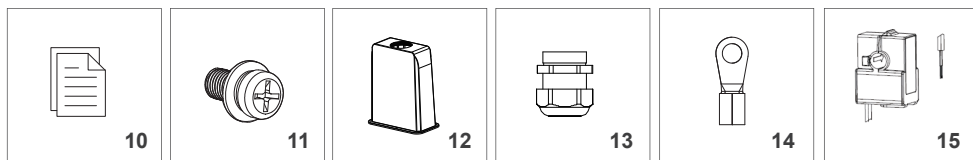
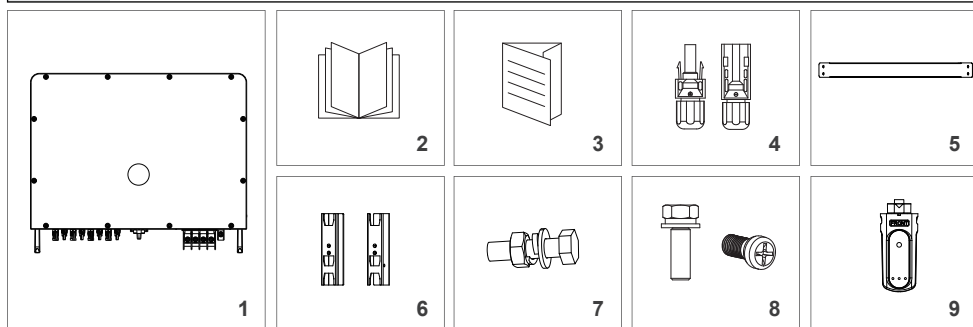

No.	Description	Model	Unit	QTY	Remark
1	Three-phase on-grid Inverter		pcs	1	
2	User manual		pcs	1	
3	Quick installation guide		pcs	1	
4	PV terminals (+, -)		pair	*1	
5	Installation hanger		pcs	1	
6	Installation bracket		pcs	2	
7	Bolt+nut+spring washer+flat washer	M10	set	4	
8	M5 Combination screws	M5×40	pcs	2	
9	Datalogger		pcs	1	
10	Inspection report		pcs	1	
11	M4 Combination screws	M4×14	pcs	10	
12	AC terminal waterproof cover		pcs	1	
13	Waterproof terminal		pcs	1	
14	OT terminal		pcs	*2	
15	CT		set	1	optional
16	Output signal connector		set	1	optional
17	Meter kit		set	1	optional
18	built-in DC fuse terminals(+)		set	1	optional

*1 The number of PV terminals allocated corresponds to the number of specific inverter terminals.

*2 The number of OT terminals dispatched is subject to the actual BOM.

Note: The pictures in the manual are only schematic drawings. The product and optional parts are subject to the actual product.

1.3 Storage

If the inverter is not put into use immediately, please store it according to the following requirements:

- Make sure that the outer packing box is not removed.
- Make sure that the storage temperature is always - 40 °C~+70 °C and the storage relative humidity is always 0~100% without condensation.
- Make sure the inverter stacking height and direction are placed according to the label on the packing box.
- Make sure there is no risk of toppling the inverter after stacking.
- Regular inspection is required during storage. If the package is damaged due to insect and rat bite, the packaging materials shall be replaced in time.
- The inverter shall be put into use after being stored for a long time and inspected and confirmed by professionals.

2 SAFETY PRECAUTIONS

The safety precautions contained in this document must always be observed when operating the equipment.



Watch out:

The inverter has been designed and tested in strict accordance with safety regulations, but as electrical equipment, the relevant safety instructions must be observed before any operation on the equipment. Improper operation may lead to serious injury or property damage.

2.1 General safety



Watch out:

- Due to product version upgrading or other reasons, the document content will be updated from time to time. If there is no special agreement, the document content cannot replace the safety precautions in the product label. All descriptions in this document are for guidance only.
- Please read this document carefully for products and precautions before installing the equipment. Professional and qualified electrical technicians who shall be familiar with the relevant standards and safety specifications of the project site must carry out all equipment operations.
- Insulation tools and personal protective equipment shall be used to ensure personal safety during inverter operation. Electrostatic gloves, wrist strap and antistatic clothing shall be worn when contacting with electronic devices to protect the inverter from electrostatic damage.
- Equipment damage or personal injury caused by inverter not installed, used or configured in accordance with the requirements of this document or corresponding user manual is not within the responsibility scope of equipment manufacturer.

2.2 PV string safety



Danger:

- Please use the DC wiring terminals provided with the box to connect the inverter DC cable. If other types of DC wiring terminals are used, serious consequences may be caused, and the equipment damage caused thereby is not within the scope of the equipment manufacturer.
- The solar array (solar panel) will have DC high voltage.



Warning:

- PV panel used with inverters must have IEC 61730 class A rating or other equivalent standard class.
- Make sure good grounding of component frame and support system.
- Do not ground the PV array positive (+) or negative (-) as this may cause serious damage to the inverter.
- Make sure that the DC cables are firmly connected without looseness after connection.
- Use a multimeter to measure the positive and negative electrodes of the DC cable. Make sure that the positive and negative electrodes are correct, no reverse connection occurs and the voltage is within the allowable range.
- Do not connect the same PV string to multiple inverters, or the inverter may be damaged.
- In order to reduce the risk of fire, the inverter connected circuit requires an overcurrent protection device (OCPD). DC OCPD shall be installed according to local requirements. All PV power supplies and circuit conductors shall have disconnect connections in accordance with NEC Article 690, Part II.

2.3 Inverter safety



Danger:

- Please connect the inverter AC cable with the AC wiring terminals provided with the box. If other types of AC wiring terminals are used, serious consequences may be caused, and the equipment damage caused thereby is not within the scope of the equipment manufacturer.
- Danger of electric shock. There are no serviceable parts inside the machine. Please do not disassemble it. Please obtain service from qualified and recognized service technicians.



Warning:

- Make sure that the voltage and frequency of the grid connection access point meet the inverter grid connection specifications.
- It is recommended to add circuit breaker or fuse and other protective devices at the AC side of the inverter, and the specification of the protective device shall be 1.25 times greater than the maximum AC output current of the inverter.
- The protective ground wire of inverter must be firmly connected to make sure that the impedance between neutral wire and ground wire is less than 10 Ω .
- Copper core cable is recommended for AC output cable.

Identifications on inverter box are as follows:



Danger of high voltage. There is high voltage when the inverter is operating. When operating the inverter, make sure the inverter is powered off.



Time delay discharge. Wait for 10 minutes after the equipment is powered off until the equipment is fully discharged.



Please read the product manual carefully before operating the equipment.



Potential hazards after equipment operation. Please take protective measures during operation.



There is high temperature on the inverter surface, so do not touch it when the equipment is running, otherwise, it may cause scald.



Connection point of protective earthing wire.



CE symbol



The equipment shall not be treated as domestic garbage. Please treat the equipment according to local laws and regulations or send it back to the equipment manufacturer.

2.4 Personnel requirements



Watch out:

- Personnel responsible for installing and maintaining equipment must first undergo strict training, understand various safety precautions, and master the correct operating methods.
- Only qualified professionals or trained personnel are allowed to install, operate, maintain, or replace equipment or components.

3 INTRODUCTION

3.1 Products introduction

The ASN series three phase on grid inverter integrates the energy management system in the PV system to control and optimize the energy flow, adapt to the requirements of the smart grid and output the power generated in the PV system to the utility/national grid.

3.2 Outlook introduction

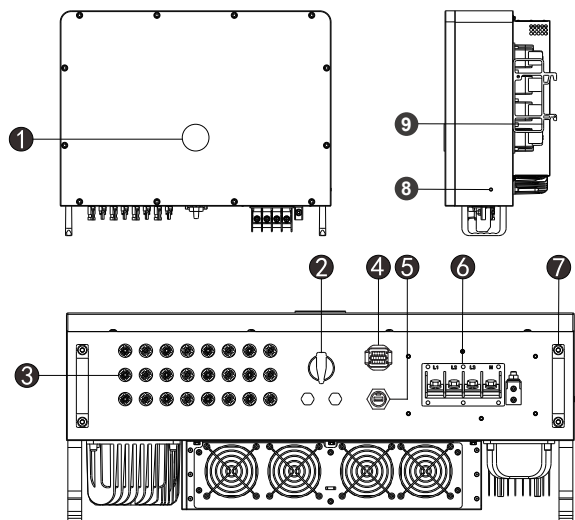

This image is for reference only. Please refer to the actual situation.

No.	Component	Description
1	LED indicator light	Indicates the working status of the inverter
2	DC switch	Control DC input on or off (warning: this switch does not have breaking capacity and is prohibited to operate when the machine is running)
3	PV DC port	Connect PV module with PV wiring connector
4	Meter communication port /RS485 port /DRM port (optional)	Smart meters/sunspec communication can be connected via RS485 / Demand response interface
5	Communication module port	The communication module can be connected via RS485, supporting optional communication modules such as bluetooth, Wi-Fi, 4G, LAN and SUNSPEC
6	Utility/national grid power interface (black)	Connect AC Utility/national grid supply
7	Handle	
8	Ground terminal	
9	Bracket	

3.3 Dimension

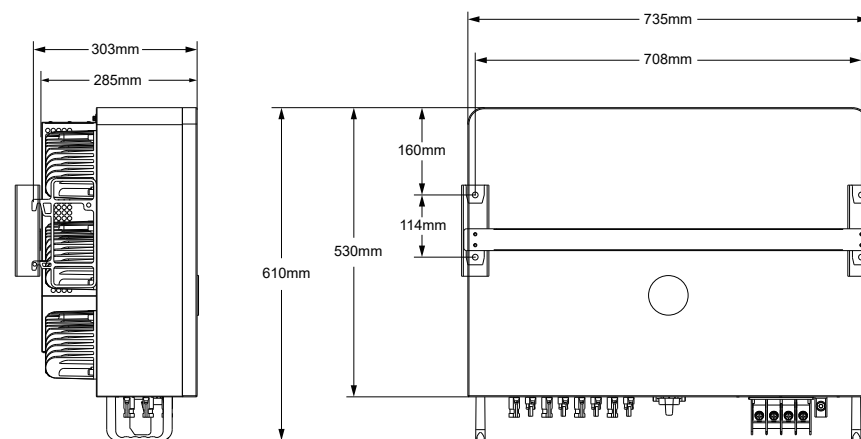

3.4 Display description

3.4.1 LED1 (Optional)

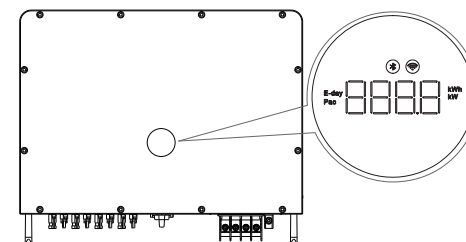

Indicator diagram	Status	Description
Bluetooth map	Off	Bluetooth not connected
	Always on	Bluetooth connected
WiFi map	Off	No communication at the communication module port
	Always on	Normal communication of communication module port
E-day	On	At this time, the central digital area displays the daily PV power generation
Pac	On	At this time, the central digital area displays the real-time grid power
Digital display tube	On	Display the specific value of this parameter
Light strip	Red always on	Fault mode (corresponding fault code displayed in the central digital area)
	Yellow flashes	Alarm mode
	Green always on	Normal operation mode
	Green flashes	Standby mode

3.4.2 LED2 (Optional)

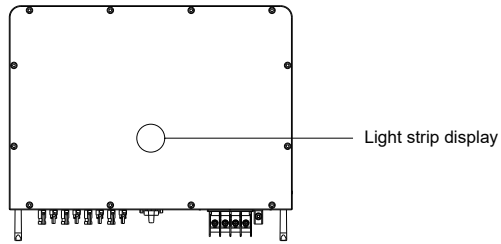

Indicator diagram	Status	Description
Light strip	Red always on	Fault mode
	Yellow flashes	Alarm mode
	Green always on	Normal operation mode
	Green flashes	Standby mode

3.4.3 LED3 (Optional)

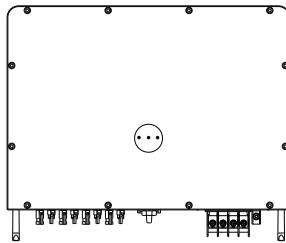

Indicator diagram	Status	Description
PWR	Green always on	The product are connected the grid normally
	Green flashes	Product standby, startup and self-test
	Extinguish	The product is disconnected from the power grid
COM	Yellow always on	The product is properly connected to the monitoring device
	Yellow flashes	Product and monitoring equipment for date transmission
	Extinguish	The communication is abnormal or no date is transmitted
ERR	Red always on	System failure shutdown
	Red flashes	System alarm
	Extinguish	System fault clearance

3.4.4 LCD (Optional)

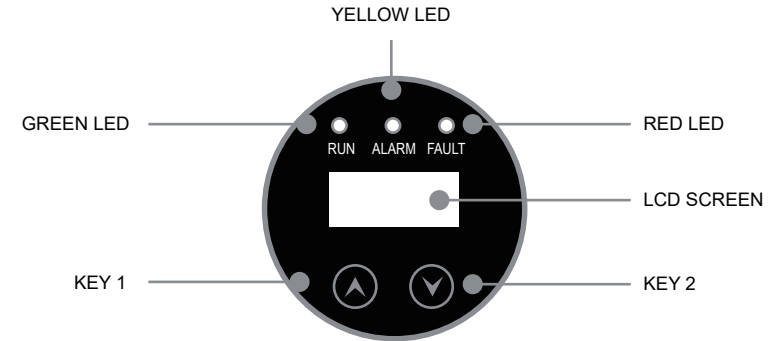

The LCD screen display module includes a display screen and two touch buttons on the front panel of the inverter, which shows the following information:

- Inverter operation status and data.
- Alarm messages and fault indications.

You can also get information via Wi-Fi/4G.

3.4.5 LCD Operation Menu

3.4.5.1 Button

The LCD screen display module has two touch buttons.

Touch buttons are as follows:

Button mode	Meaning
Touch button 1	UP
Touch button 2	DOWN
Press and hold button 1 for 2s	BACK
Press and hold button 2 for 2s	ENTER

3.4.5.2 LED display light

LED display light has red, green, yellow three colors.

LED display light display effect is steady on, off and blinking (on 0.5s off 0.5s), as described in the following table:

Device status	LED	Priority
Upgrades	Red, green and yellow flash alternately	1
Breakdown	Red light steady on	2
Alarm	Yellow light flashing	3
Power generation	Green light steady on	4
Standby	Green light flashing	5

Remarks: Priority 1 is the highest, and it decreases in turn.

3.4.6 LCD work menu

The LCD is located on the front panel of the inverter, which shows the following information:

- Inverter operation status and data.
- Alarm messages and fault indications.

During normal operation, the display alternately shows the power and the operation status for 5 seconds. The LCD screens can also be manually scrolled by pressing UP and DOWN buttons. Press and hold button 2 for 2s gives access to the main menu or press and hold button 1 for 2s calls back to the previous menu.

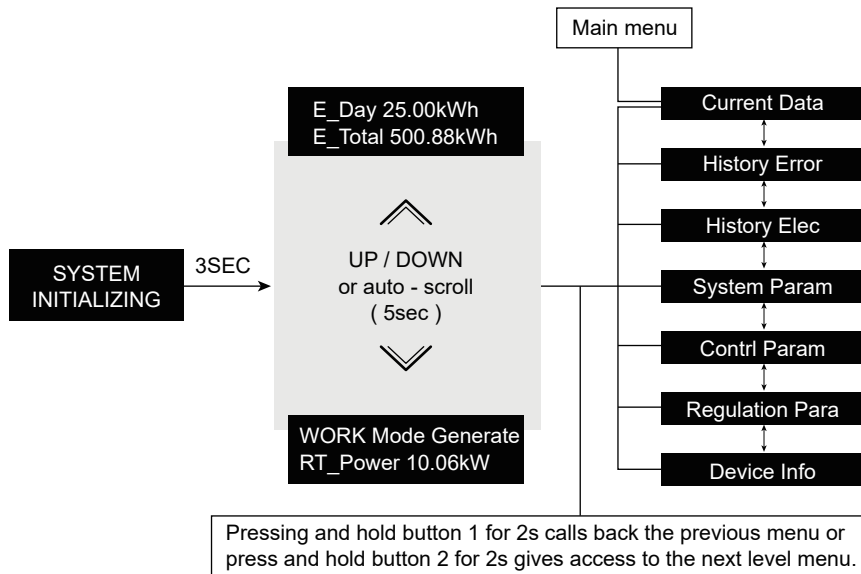

3.4.7 Main menu

There are 7 submenus in the main menu:

- Current Data
- History Error
- History Elec
- System Param
- Contrl Param
- Regulation Para
- Device Info

3.4.8 Current data

The AUX ASN series three phase on grid inverter main menu provides access to operating data and information. Select Current Data from the menu to display the information and scroll up or down.

No.	Display	Description
1	Mode Generate	Display the current operating mode of inverter
2	GRID VOLT 220.0V	Display grid voltage value
3	GRID P 4.98KW	Display the instant output power value
4	GRID FREQ 50.00HZ	Display grid frequency value
5	E_DAY 25.78kWh	Total Elec on that day
6	E_TOTAL 8458.57kWh	Total Elec
7	PV1 VOLT 250.5V	Display PV1 voltage value
8	PV2 VOLT 260.8V	Display PV2 voltage value
9	PV1 CUR 10.7A	Display PV1 current value
10	PV2 CUR 10.5A	Display PV2 current value

3.4.9 History error

2022-03-04 19:33:39 10. IsolationAlarm	LCD display shows the latest 31 alarm messages. Press UP/DOWN to manually scroll through the screen. Press and hold button 1 for 2s to the previous menu.
---	---

3.4.10 History electricity

Select the date of daily generation

2022-03-05 23.51kWh	1. His Daily Elec This function is used to view the generated energy on the selected date. Press UP/DOWN to change the date.
------------------------	--

Select the month of monthly generation

2022-03 223.51kWh	2. His Month Elec This function is used to view the energy production for the selected month. Press UP/DOWN to change the month.
----------------------	--

Select the year of annual energy production

2022 1323.51kWh	3. His Year Elec This function is used to view the energy production for the selected year. Press UP/DOWN to change the year.
--------------------	---

3.4.11 System parameters

3.4.11.1 Set address

This function is used to set the address when multiple inverters are connected to a single monitor. The address number can be assigned from "01" to "10".

1.Comm Ad dr 1	The default address number of AUX ASN series three phase on grid inverter is "01". Press the UP/ DOWN buttons to set the address. Press and hold button 2 for 2s to save the settings. Press and hold button 1 for 2s to cancel the change and return to the previous menu.
-------------------	---

3.4.11.2 Selecting regulation

This function is used to select the reference regulation for the grid.

2.Regulation CQC	Press UP/DOWN to select the regulation. (CQC,Brazil,EN_50549,IEC61727_50,IEC61727_60,Wide_Range_50,Wide_Range_60,Spain,Poland).
---------------------	--

	Attention: This function is for technical personnel only. For different countries, grid regulations need to be set differently according to local requirements. If in doubt, consult your AUX technician. Below is the setting range for "User-Def". The following are user-defined setting ranges. With this function the limits can be changed manually. (CQC,Brazil,EN_50549,IEC61727_50,IEC61727_60,Wide_Range_50,Wide_Range_60,Spain,Poland).
---	--

3.4.11.3 Set language

3.Language English	Press UP/ DOWN to set the language. Press and hold button 2 for 2s to save the settings. Press and hold button 1 for 2s to cancel the change and return to the previous menu.
-----------------------	---

3.4.11.4 Set time

This function allows to set time and date. When this function is selected, the LCD displays the following <Time Set>

4.Time Set 2023/04/24 11:01:03	Set Time		
Date-Month 4	Set Month	Date-Year 2023	Set Year
Time-Hour 11	Set Hour	Date-Day 24	Set Day
Time-Second 3	Set Second	Time-Minute 1	Set Minute

Press UP/ DOWN to set the time and data. Press and hold button 2 for 2s to save the settings and press and hold button 1 for 2s to return to the previous menu.

3.4.12 Control parameters

	Attention: Only fully qualified and approved technicians shall enter the area. Password is required to enter the menu "Control Param". Select "Control Param" on the Main Menu.The screen will require the password:
---	--

Password 1020	The default password is"1020". Please press DOWN to move the cursor and press UP to select the number. After enter the correct password the main menu will display a screen and be able to access to the following information: 1. remote control 2. clear His.error 3. restore factory
------------------	--

3.4.12.1 Remote control

This function is used to start or stop AUX three phase on grid inverter power generation.

Remote control Power on	Press UP/DOWN to manually scroll the screen. Press and hold button 2 for 2s to save the setting. Press and hold button 1 for 2s to return to the previous menu.
----------------------------	---

3.4.12.2 Clear his.error

This function is used to clear the fault record.

His Elec Clear?
Cancel affirm

Press and hold button 2 for 2s to save the setting , Press and hold button 1 for 2s to return the previous menu.

3.4.12.3 Restore factory

Restore factory settings to set special settings for all items to default values. The screen shows as below:

Restore?
Cancel affirm

Press and hold button 2 for 2s to save the setting. Press and hold button 1 for 2s to return the previous menu.

3.4.13 Regulation parameters



Attention:

Only fully qualified and approved technicians shall enter the area. Password required to enter the menu "Regulation Para". Select "Regulation Para" to enter the main menu. The password required on the screen is:

Password
1020

The default password is"1020". Please press DOWN to move the cursor, press UP to select numbers. When the correct password is entered, the main menu displays an interface to access the following information:

No.	Display	Description
1	GridOverVolt_1 110%	Display the primary over voltage protection value of power grid
2	GridOverVolt_T1 1000ms	Display the primary over voltage protection time of power grid
3	GridOverVolt_2 135%	Display the secondary over voltage protection value of power grid
4	GridOverVolt_T2 40ms	Display the secondary over voltage protection time of power grid
5	GridOverVolt_3 135%	Display the three-level over voltage protection value of power grid
6	GridOverVolt_T3 40ms	Display the three-level over voltage protection time of power grid
7	GridUnderVolt_1 85%	Display the primary under voltage protection value of power grid
8	GridUnderVolt_T1 1000ms	Display the primary under voltage protection time of power grid
9	GridUnderVolt_2 50%	Display the secondary under voltage protection value of power grid
10	GridUnderVolt_T2 80ms	Display the secondary under voltage protection time of power grid
11	GridUnderVolt_3 20%	Display the three-level under voltage protection value of power grid
12	GridUnderVolt_T3 40ms	Display the three-level under voltage protection time of power grid
13	GridOverVFreq_1 50.50HZ	Display the primary over-frequency protection value of power grid

No.	Display	Description
14	GridOverVFreq_T1 180ms	Display the primary over-frequency protection time of power grid
15	GridOverVFreq_2 55.00HZ	Display the secondary over-frequency protection value of power grid
16	GridOverVFreq_T2 140ms	Display the secondary over-frequency protection time of power grid
17	GridOverVFreq_3 55.00HZ	Display the three-level over-frequency protection value of power grid
18	GridOverVFreq_T3 140ms	Display the three-level over-frequency protection time of power grid
19	GridUnderFreq_1 47.50HZ	Display the primary under-frequency protection value of power grid
20	GridUnderFreq_T1 180ms	Display the primary under-frequency protection time of power grid
21	GridUnderFreq_2 45.00HZ	Display the secondary under-frequency protection value of power grid
22	GridUnderFreq_T2 140ms	Display the secondary under-frequency protection time of power grid
23	GridUnderFreq_3 45.00HZ	Display the three-level under-frequency protection value of power grid
24	GridUnderFreq_T3 20ms	Display the three-level under-frequency protection time of power grid
25	Restart Time 60s	Display start time
26	Reconnected Time 60s	Display reconnection time

Press UP/DOWN to manually scroll the screen. Press and hold button 2 for 2s to enter the parameter modification interface, than press DOWN to move the cursor, press UP to select numbers, press and hold button 2 for 2s to save the settings, press and hold button 1 for 2s to cancel the change and return to the previous menu.

3.4.14 Device info

3.4.14.1 Software version

1.Software Version A1259	This screen displays the inverter software version number.
-----------------------------	--

3.4.14.2 Rated power

2.Rated Power 10 kW	The screen displays the inverter's rated power.
------------------------	---

3.4.14.3 SN number

3.SN Number ASN-10TL2304460018	The screen shows the SN Number of the inverter.
-----------------------------------	---

4 APPLICATION

4.1 Grid form

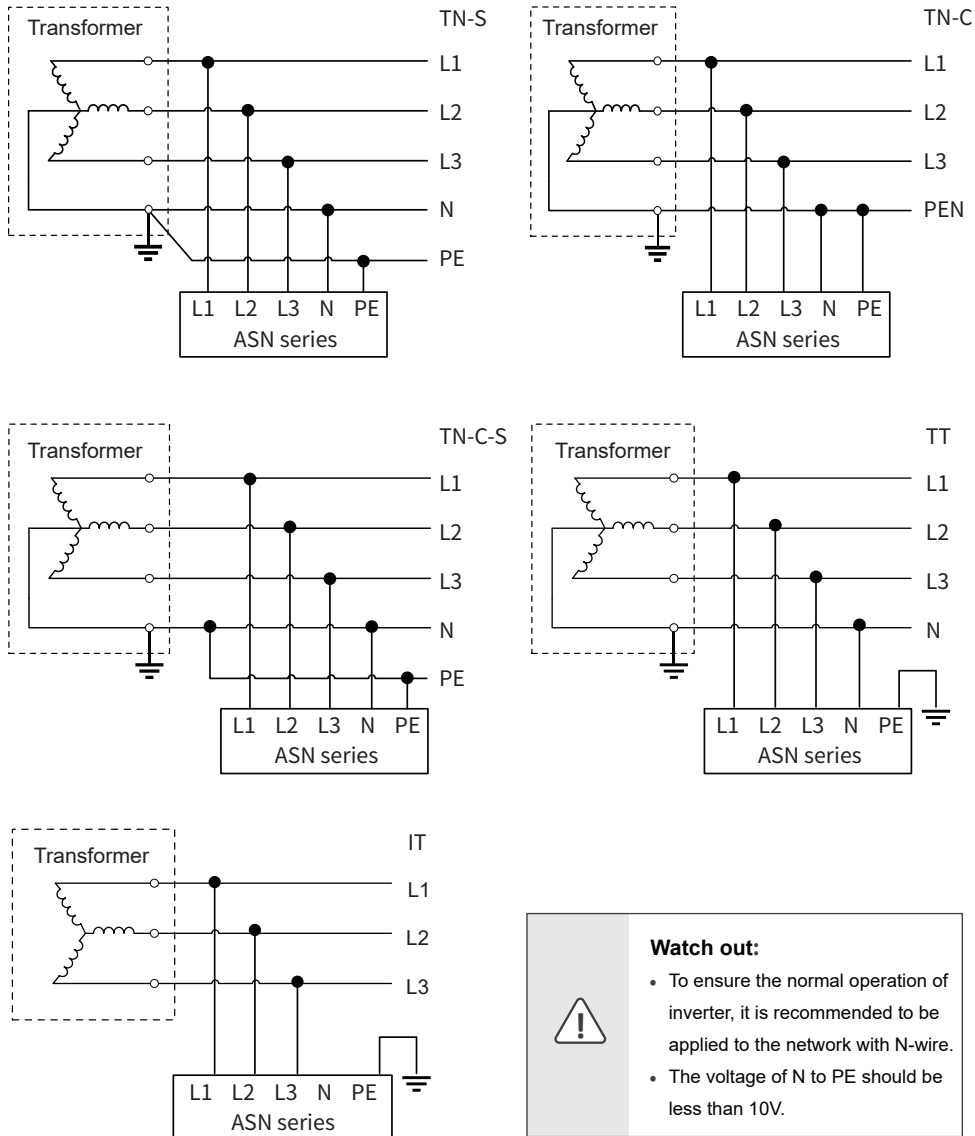

4.2 Application scenario



Warning:

- PV systems are not suitable for connecting devices that rely on stable power supply, such as life-sustaining medical equipment. Please ensure that the power outage of the system does not cause personal injury.
- When the inverter is protected for a single time, the inverter can be automatically restarted.

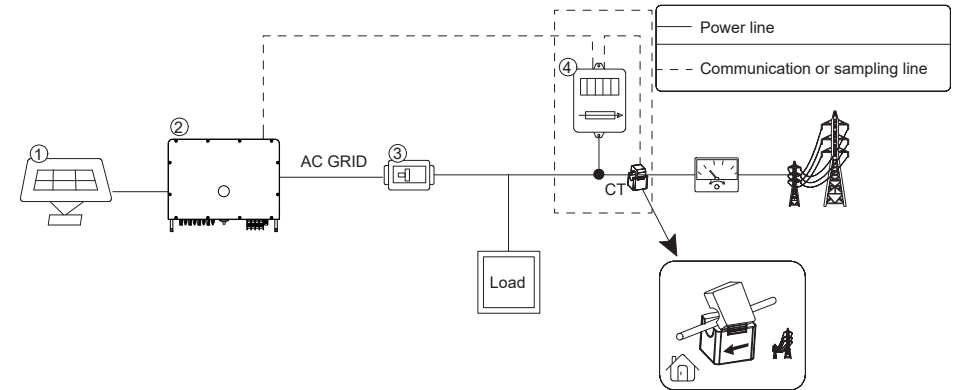

No.	Component	Description
1	PV string assembly	PV string consists of PV modules connected in series
2	Inverter	ASN series on grid inverter
3	AC circuit breaker	Used for inverter and load protection and for interrupting AC supply during maintenance
4	Smart meter	Optional

AC circuit breaker

Model	Voltage(Vac)	Current(A)
ASN-50TL-G2	≥400	≥200
ASN-60TL-G2	≥400	≥200
ASN-70TL-G2	≥400	≥200
ASN-75TL-G2	≥400	≥200
ASN-80TL-G2	≥400	≥200
ASN-30TL-LV-G2	≥400	≥200
ASN-40TL-LV-G2	≥400	≥200

4.3 Application mode

4.3.1 Full grid connection

If no load is required, all energy of the inverter can be supplied to the utility/national grid to realize full grid connection of power generation.

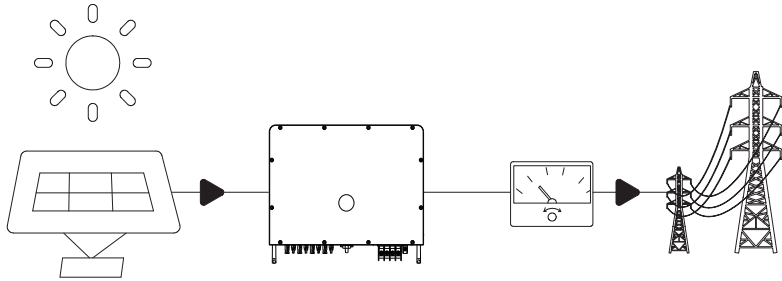

4.4 Function characteristics

4.4.1 Power derating

The inverter will automatically reduce the output power when the operating environment is not ideal.

The following factors may cause power derating, so please try to avoid them during use:

- Unfavorable environmental conditions such as direct sunlight, high temperatures, etc.
- The inverter's output power percentage has been limited by the app or web-end settings.
- Variation with grid voltage frequency.
- High input voltage.
- High input current value.

5 INSTALLATION

5.1 Installation requirements

5.1.1 Environmental requirements

- The protection class of inverter is IP66, which can be installed indoor and outdoor.
- Equipment shall not be installed in flammable, explosive and corrosive environment.
- The installation position shall be kept away from the accessible range of children and the position easy to be touched. High temperatures may be present on the surface when the equipment is in operation to prevent burns.
- The installation position shall avoid the water pipe and cable in the wall to avoid danger during punching.
- The inverter shall avoid salt fog areas and installation environments such as sunshine, rain and snow. It is recommended to install the inverter in a sheltered installation position. If necessary, a sunshade can be erected.
- When installing the inverter, certain space shall be reserved around the inverter to ensure sufficient installation and heat dissipation space.
- Under the installation scenario of multiple inverters, when the space is sufficient, the installation mode of "straight line" is recommended, When the space is insufficient, it is recommended to install the product in a zig-zag manner. It is not recommended to install multiple inverters by overlapping.
- The installation height of the equipment shall be convenient for operation and maintenance, ensure that the equipment indicator lights, all labels are easy to see, and the terminal blocks are easy to operate.
- The inverter is installed at an altitude lower than the maximum working altitude of 4000m.
- Keep away from strong magnetic field environment to avoid electromagnetic interference. If there is a radio station near the installation location or wireless communication equipment below 30MHz, please install the equipment according to the following requirements:

Ferrite core with multi-circle winding or low-pass EMI filter at inverter DC input or AC output.

The distance between inverter and wireless electromagnetic interference equipment exceeds 30m.

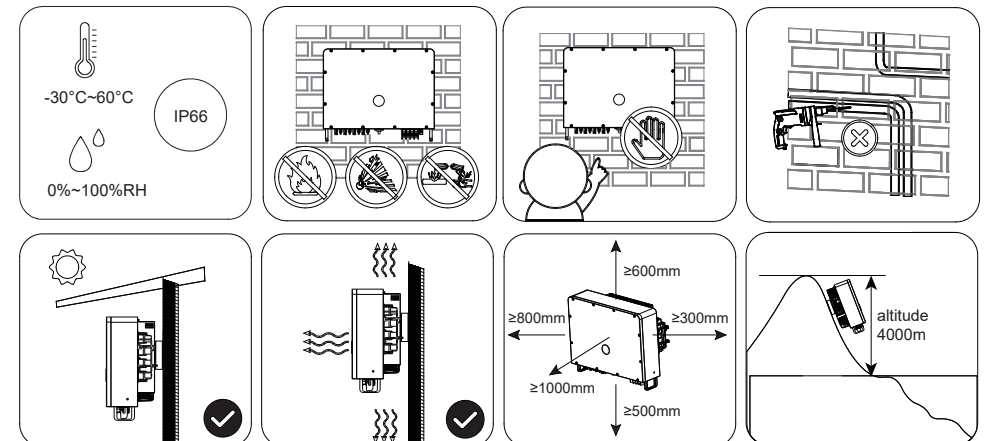

5.1.2 Carrier requirements

- Installation carriers must not be flammable and must be fire resistant.
- Please make sure that the mounting carrier is solid and reliable and can bear the weight of inverter.
- The equipment will vibrate during operation, so do not install it on the carrier with poor sound insulation, so as to avoid disturbance to residents in the living area caused by the noise generated by the equipment during operation.

5.1.3 Installation angle requirements

- Recommended inverter installation angle: vertical or pitching $\leq 15^\circ$.
- Do not invert, tilt forward, tilt backward beyond the angle and install the inverter horizontally.

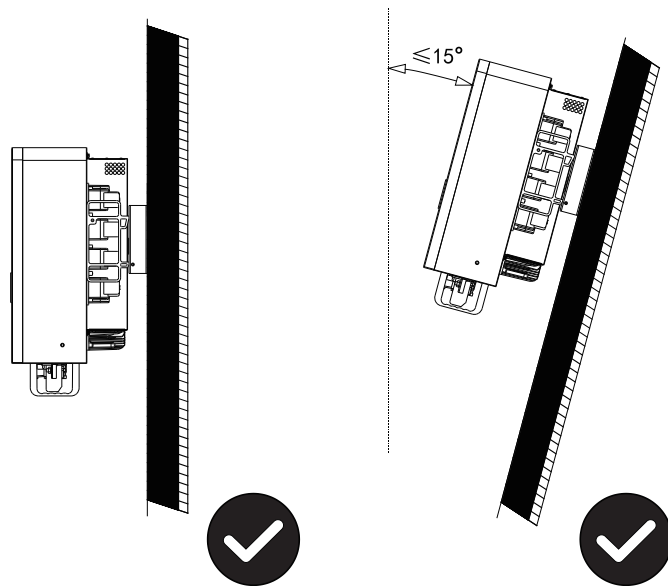

5.1.4 Installation tool requirements

The following installation tools are recommended for installation. Other auxiliary tools can be used on site if necessary.

 Percussion drill	 Sockets tool box	 Torque screw driver	 Diagonal pliers	 Wire stripper
 Crimping pliers	 Pressing terminal crimping plier	 Hydraulic tongs	 Wire cutter	 Multimeter (Vdc range 1500V)
 Rubber hammer	 Vacuum cleaner	 Tape measure	 Levelling instrument	 Electrician's knife
 Heat shrinkable sleeve	 Air heater	 Cable ties	 Goggles	 Insulating gloves
 Protective gloves	 Respirator	 Protective shoes		

5.2 Installation of inverter

Watch out:

- Transportation, turnover, installation and other operations must meet the requirements of national and regional laws and regulations and relevant standards.
- Please equip corresponding personnel according to the weight of the equipment to prevent the equipment from exceeding the weight range that can be handled by human body and damaging personnel.
- Wear safety gloves to avoid injury.
- Please make sure that the equipment is balanced during handling to avoid dropping.



Watch out:

- When drilling holes, make sure that the drilling position is kept away from water pipes, cables, etc. in the wall to avoid danger.
- Wear goggles and dust mask when punching to avoid dust inhalation into respiratory tract or into eyes.
- Make sure that the inverter is securely installed to prevent injuries from falling.

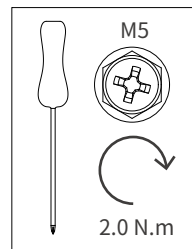
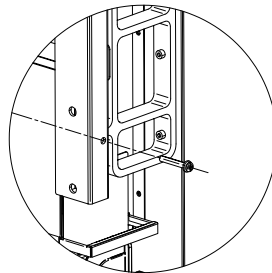
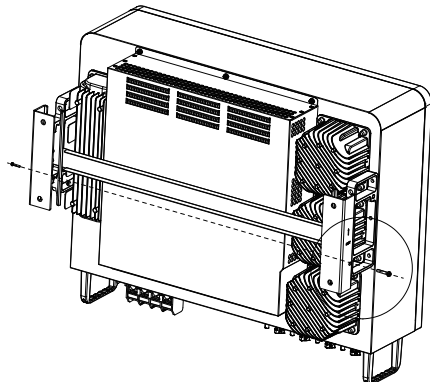
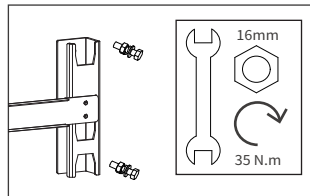
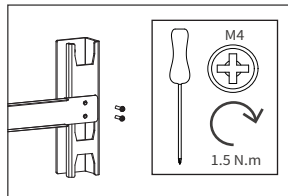
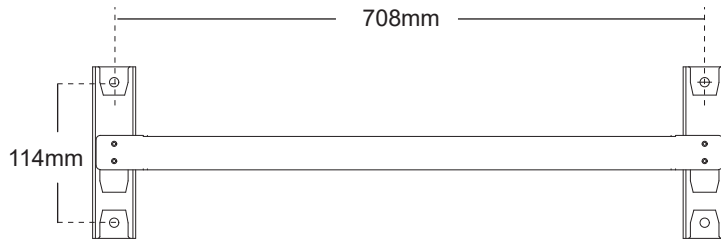

5.3 Electrical connection

5.3.1 Safety precautions

Danger:

- Specifications of all operation, cables and components used in electrical connection shall comply with local laws and regulations.
- Before electrical connection, please disconnect the DC switch and AC output switch of inverter to make sure that the equipment is powered off. It is strictly forbidden to operate with electricity, otherwise, electric shock and other hazards may occur.
- Cables of the same type shall be bound together and arranged separately from cables of different types. It is forbidden to wind or cross cables.
- If the cable bears too much tension, it may lead to poor wiring. When wiring, please reserve a certain length of the cable before connecting to the inverter wiring port.
- When crimping the connecting terminal, please make sure that the conductor part of the cable is fully contacted with the connecting terminal, and do not crimp the cable insulation skin together with the connecting terminal, otherwise, the equipment may be unable to operate, or the inverter terminal block may be damaged due to heating due to unreliable connection after operation.



Watch out:

- When making electrical connection, please wear safety shoes, protective gloves, insulating gloves and other personal protective equipment as required.
- Only professionals are allowed to carry out operations related to electrical connection.



5.3.2 Connect protective earth wire

Warning:

- The protective grounding of the crate shell cannot replace the protective grounding wire of the AC output port. When wiring, ensure that the protective grounding wires at the two places are reliably connected.
- In case of multiple inverters, make sure that the protective earthing point of all inverter crate enclosures is equipotentially connected.
- To improve the corrosion resistance of the terminal, it is recommended to apply silicone or paint on the external of the grounding terminal for protection after the connection and installation of the protective ground wire.
- Please prepare the protective ground wire, and the recommended specification:
Type: Outdoor single-core copper wire
Conductor sectional area: 25-35mm² (Phase cable diameter/2)

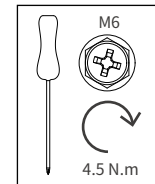
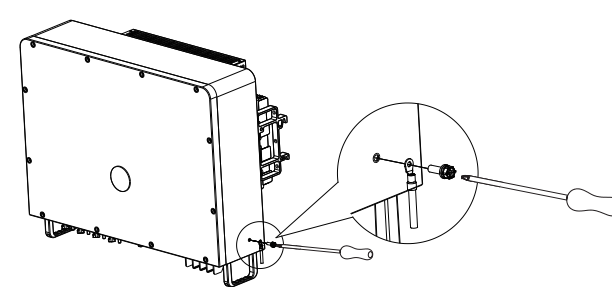

5.3.3 Connect PV input cable

Danger:

- Do not connect the same PV string to multiple inverters, otherwise the inverter may be damaged.
- Please make sure that the maximum short circuit current and maximum input voltage of each MPPT are within the allowable range of the inverter.
- Please make sure that the positive electrode of the PV string is connected to the PV port+of the inverter, and the negative electrode of the PV string is connected to the PV port - of the inverter.
- Please prepare your own PV input cable. Recommended specification:
Type: Outdoor PV multi-core copper wire
conductor cross-section: 4-6mm² (12 - 10AWG)
Outer diameter of conductor insulation layer: φ3~7mm



Warning:

- PV string output does not support grounding. Before connecting PV string to inverter, please make sure that the minimum insulation resistance to ground of PV string meets the minimum insulation impedance requirements ($R = \text{maximum input voltage} / 30\text{mA}$).
- Make sure that the DC cables are firmly connected without looseness after connection.
- Use a multimeter to measure the positive and negative electrodes of the DC cable and ensure that the positive and negative electrodes are correct without reverse connection, and the voltage is within the allowable range.



1

$$4\text{mm}^2 \leq S \leq 6\text{mm}^2$$

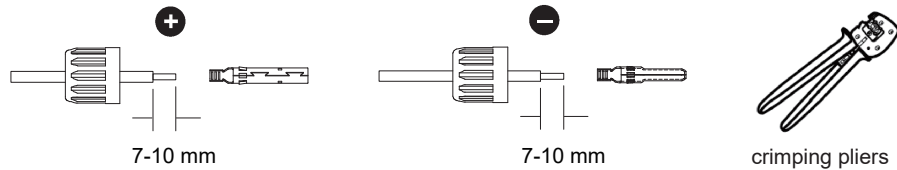

2

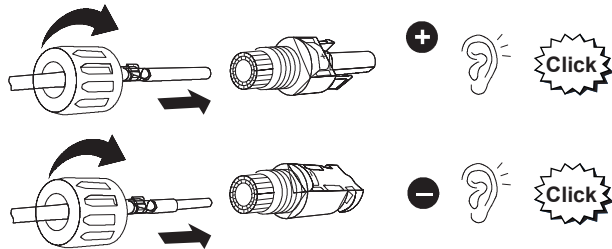

3

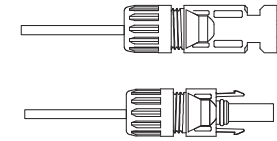
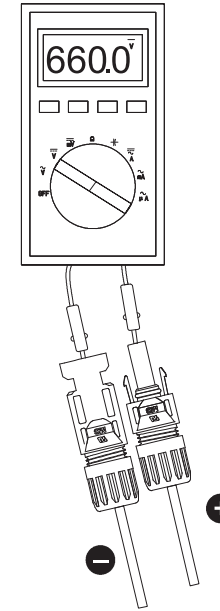

Make sure PV polarity is right,
PV voltage ≤ 800V for -LV type.
Others: PV voltage ≤ 1100V
The recommend PV voltage is 450V
for -LV type.
Others: The recommend PV voltage
is 800V

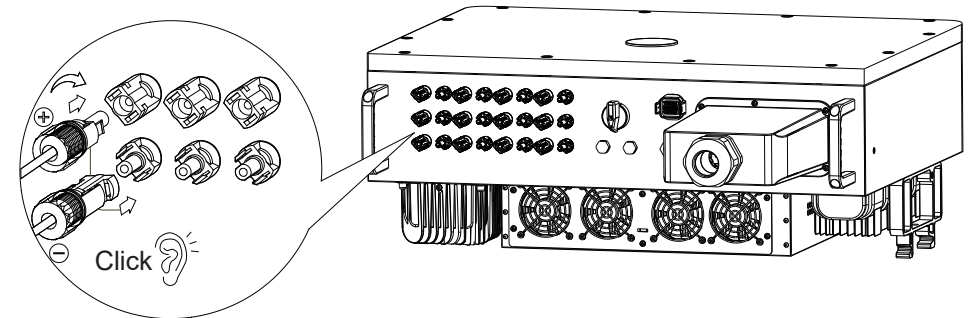

5.3.4 Connect AC cable



Danger:

- In order to ensure that the inverter and the grid can be safely disconnected from the grid in case of abnormal conditions, please connect the AC switch on the AC side of the inverter. Multiple inverters cannot be connected to one AC switch at the same time. Please select proper AC switch according to local regulations.
- Please prepare the AC output cable. See the figure for the recommended specification.
- If multi-core copper wire is selected, supporting crimping terminal shall be used for assembly. It is forbidden to directly press multi-core copper wire into the connector.



Warning:

- Residual current monitoring unit (RCMU) is integrated in the inverter. When the inverter detects leakage current greater than the allowable value, it will quickly disconnect from the grid.
- During wiring, the AC cable is completely matched with "L1", "L2", "L3", "N" and grounding port of AC terminal. If the cable is connected improperly, the equipment will be damaged.
- Make sure that the core is completely inserted into the terminal hole without exposure.
- Ensure that the cables are firmly connected, otherwise the terminal may be overheated and the equipment may be damaged when the equipment is operating.

1

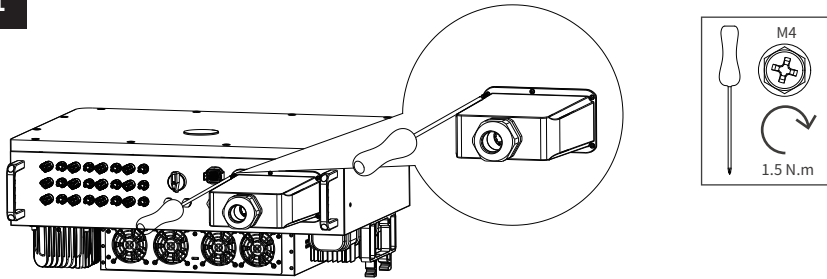

2

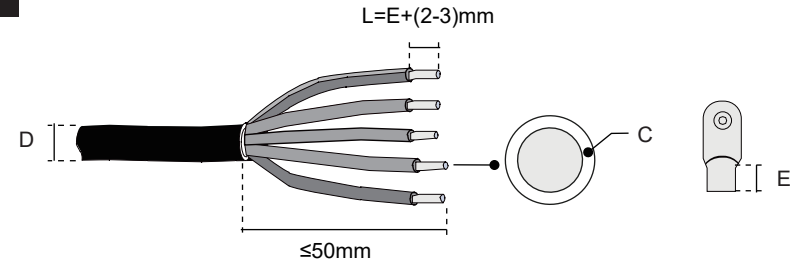

Copper core:

Model	C	D
ASN-(50~60)TL-G2	50mm ²	38-56mm
ASN-(70~80)TL-G2	50-70mm ²	38-56mm
ASN-(30~40)TL-LV-G2	50mm ²	38-56mm

3

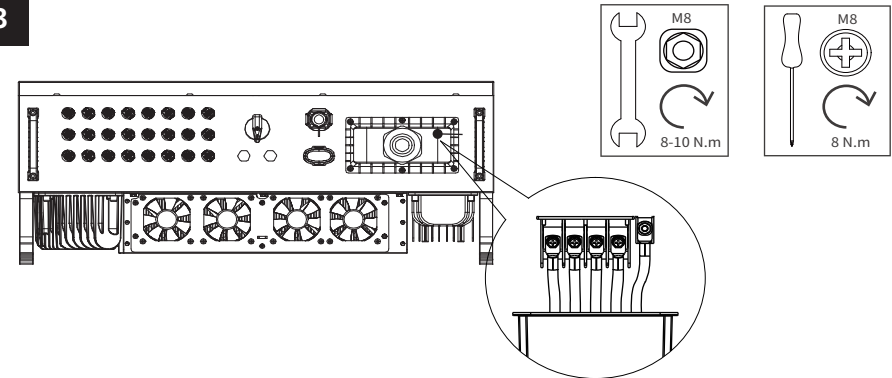

4

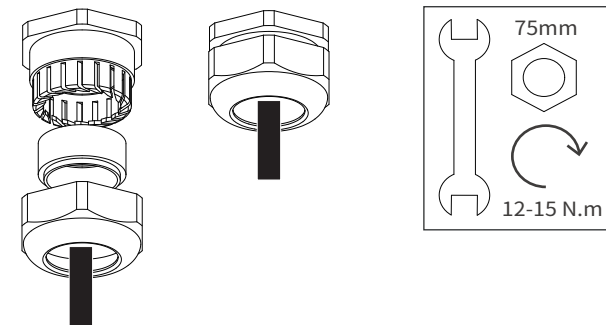

5.3.5 Smart meter (optional)

There are two communication ports on the inverter, one is the USB COM1 port and the other is the 16-core COM2 port.

The USB COM1 port is used to connect the data acquisition stick, and the 16-core COM2 port is used for multi-inverter RS485 daisy chain connection/electric meter communication interface.

The 16-core COM2 interface is defined as follows:

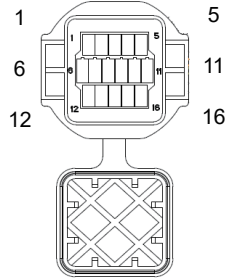

Pin	Function	Description	Pin	Function	Description
1	485A1_1	Interfaces for inverter cascading, grid dispatching, and external data acquisition(optional)	9	DRM 1/5	DRM (optional)
2	485B1_1		10	DRM 2/6	
3	485A1_2		11	DRM 3/7	
4	485B1_2		12	DRM 4/8	
5	485 1 GND		13	DRM 0	
6	485A2	14	DRM_GND	Interface for connecting an anti-backflow meter (optional)	
7	485B2	15	DRM_+5V		
8	485 2 GND	16	DRM_GND		



Watch out:

When connecting communication lines, please ensure that the wiring port definition completely matches the device, and the cable routing path should avoid interference sources, power lines, etc., so as not to affect signal reception.

ASN three-phase inverter can meet the requirements of the zero export through one intelligent meter and three CTs. It can be set as single phase anti-backflow and three-phase anti-backflow as required. Taking 80kW model as an example:

Single phase anti-backflow: three-phase on grid power is independently adjusted. For example, if the load of L1/L2/L3 phase is 20kW/24kW/28kW respectively, then the output power of L1/L2/L3 will be 20kW/20kW/20kW respectively (the maximum single-phase on grid power of 80kW model is 26.7kW). The remaining power required will be purchased from the grid.

Three-phase anti-backflow sum regulation of three-phase grid-connected power. If L1/L2/L3 phase load is 20kW/24kW/28kW respectively, then L1/L2/L3 output power will be 24kW/24kW/24kW respectively (80kW model single-phase maximum grid connection power is 26.7kW). The remaining power required will be purchased from the grid.

5.3.5.1 Anti-backflow wiring diagram (single inverter)

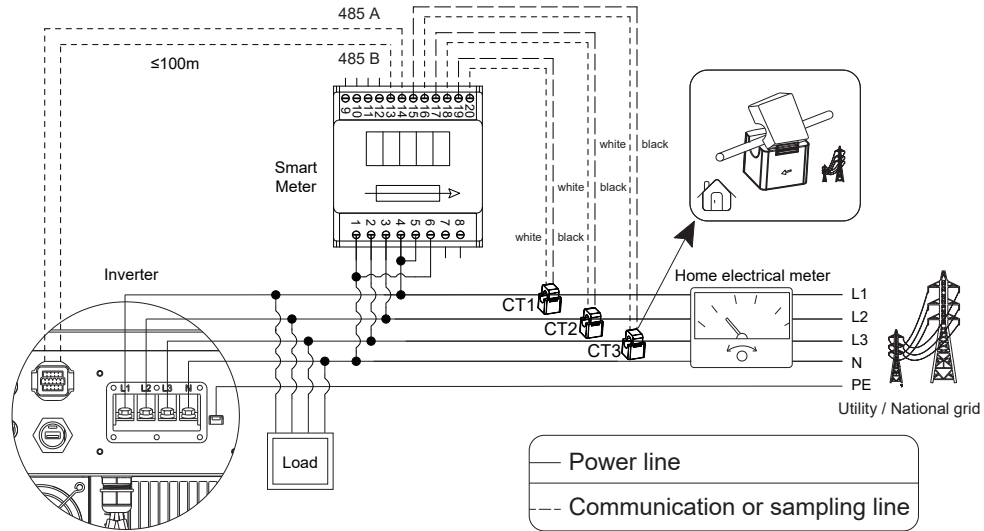

5.3.5.2 Anti-backflow wiring diagram (multi-inverter)

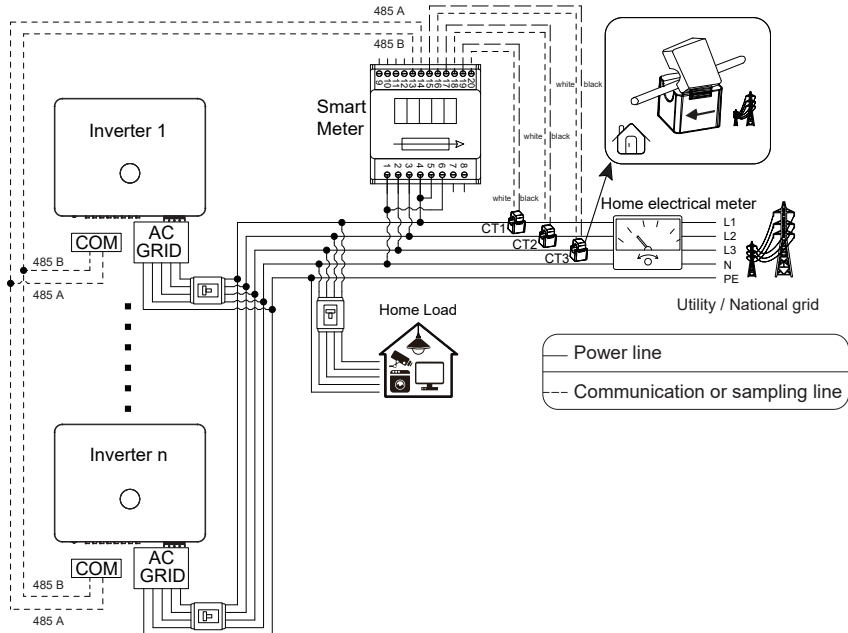

5.3.6 Datalogger connection (optional)



Watch out:

Detailed introduction of communication module can be obtained from the official website.

1. Open the COM1 port cover plate, assemble the datalogger and USB port together as shown in the figure, and tighten the datalogger.
2. The datalogger can support Wifi, 4G, LAN or SUNSPEC communication. Refer to the datalogger installation guide for detailed operation.

1

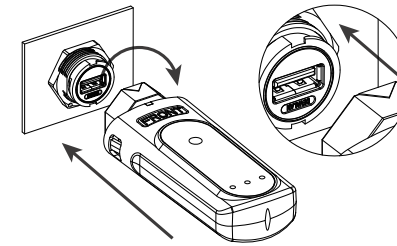

2

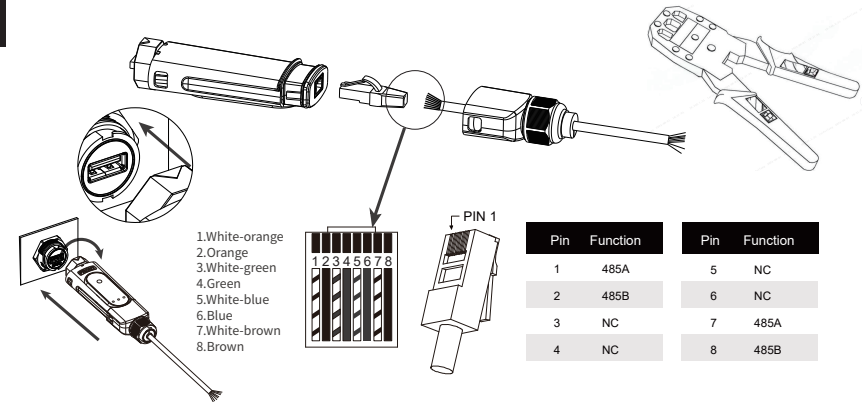

6 EQUIPMENT COMMISSIONING AND MAINTENANCE

6.1 Check before power-on

Items	Checking items	Standard
1	Installation of inverter	The inverter shall be installed correctly, firmly and reliably
2	Cable arrangement	Cables shall be reasonably arranged and well protected, without damage
3	Datalogger	The data logger shall be installed correctly, firmly and reliably
4	Identifying	The safety signs and warning labels on the inverter are not blocked or damaged
5	Switch	"DC SWITCH" and all switches connected to the inverter are "OFF"
6	Cable connection	The AC output cable, DC input cable and grounding wire are connected correctly, firmly and reliably
7	Unused terminals and interfaces	Unused terminals and interfaces are protected with waterproof covers
8	Circuit breaker	Reasonable selection of AC circuit breaker
9	Environmental requirements	Reasonable installation space, clean and tidy environment, no construction remains

6.2 Power on the equipment

- Step 1: At the AC switch between the inverter and the power grid, measure the voltage at the power grid side with a multi-meter, and confirm that the power grid voltage is at the working power of the inverter Allowable pressure range.
- Step 2: Close the AC switch between inverter and utility/national grid.
- Step 3: Set "DC SWITCH" on the inverter to "ON".
- Step 4: Observe the inverter LED indicator and check the inverter operation status.

6.3 Set inverter parameters via APP



Watch out:

To ensure that the inverter works properly, please use the application program to complete the inverter parameter setting.

Scan the QR code below to download the application or log in following website to download this application:

<https://www.auxsolcloud.com>



Watch out:

Please also obtain the operating instructions of the communication rod from the official website, to set the contents more consistent with the application scenario.

6.4 Power off the equipment



Danger:

- When operating and maintaining the inverter, please turn off the inverter for treatment. Live operation of the equipment may cause damage to the inverter or electric shock.
- After the inverter is powered off, it will take a certain amount of time for internal components to discharge. Please wait until the equipment is fully discharged according to the required label time requirements.

- Step 1: Disconnect the AC switch between the inverter and the utility/national grid.
- Step 2: At the AC switch between the inverter and the utility/national grid, measure the voltage on the power grid side with a multi-meter to confirm that the power has been cut off.
- Step 3: Observe the inverter LED indicator, and confirm to enter standby.
- Step 4: Set "DC SWITCH" on inverter to "OFF".

6.5 Equipment removal



Danger:

- Make sure inverter is power off.
- Wear personal protective equipment when operating the inverter.

Step 1: Successively remove all electrical connections of inverter, including DC cable, AC cable, communication cable, communication module and protective earth wire.

Step 2: Remove the inverter from the back cladding.

Step 3: Remove the back cladding.

Step 4: Properly save the inverter and ensure that the storage conditions meet the requirements if the subsequent inverter is still put into use.

6.6 Equipment scrapping

If the inverter cannot be used anymore and needs to be scrapped, please dispose according to the electrical waste disposal requirements of the inverter country/region.

The inverter shall not be treated as household garbage.

6.7 Trouble shooting

Please troubleshoot according to the following methods. If the troubleshooting methods cannot help you, please contact the after-sales service center.

When contacting the after-sales service center, please collect the following information for quick solution.

1. Inverter information, such as serial number, software version, equipment installation time, fault occurrence time, fault occurrence frequency, etc.
2. Equipment installation environment, such as weather conditions, whether components are sheltered and whether there is shadow, etc. It is recommended to provide photos, videos and other documents to assist in analyzing problems.
3. Utility/National grid condition. If there is only indicator mode for inverter, fault information can be viewed through back platform/APP mode.

Defect codes	Defect name	Fault cause	Solutions
0101	BUS software overvoltage	1. Abnormal fluctuations in the power grid or load. 2. Weak illumination or abnormal changes in illumination. 3. Photovoltaic array configuration errors, excessive number of photovoltaic panels in series. 4. Poor photovoltaic ground insulation.	1. If it happens accidentally, it may be caused by abnormal power grid, load or light for a short time. After the self-check is normal, the inverter will return to normal operation without manual intervention. 2. Check the series configuration of the corresponding photovoltaic array string to ensure that the open circuit voltage of the string is not higher than the maximum working voltage of the inverter. 3. Check the impedance of the photovoltaic string to the protection ground. If there is a short circuit, please rectify the short circuit point.
0102	BUS undervoltage		
0103	BUS imbalance		
0104	BUS hardware overvoltage		

Defect codes	Defect name	Fault cause	Solutions
0301	R-phase inverter soft start timeout	1. Abnormal power grid fluctuations. 2. Inverter sampling fault. 3. Wiring fault.	1. If it occurs accidentally, it may be caused by the abnormal power grid or load for a short time. After the self-check is normal, the inverter will resume normal operation without manual intervention. 2. Disconnect the AC circuit breaker and photovoltaic input switch in turn, after 10 minutes, close the AC circuit breaker and photovoltaic input switch in turn to check whether the fault is still. 3. Please check whether the photovoltaic and AC cables are correctly connected according to the wiring requirements of the manual.
0302	S-phase inverter soft start timeout		
0303	T-phase inverter soft start timeout		
0601	R-phase inverter software overcurrent	1. Abnormal fluctuations in the power grid or load. 2. Inverter sampling fault.	1. If it occurs accidentally, it may be caused by a short-term abnormality of the power grid or load. After the self-check is normal, the inverter will return to normal operation without manual intervention. 2. If it occurs frequently, check whether the voltage frequency of the power grid is stable. If the power grid fluctuates greatly, enable the weak power grid mode and restart the inverter?
0602	S-phase inverter software overcurrent		
0603	T-phase inverter software overcurrent		
0701	R-phase inverter hardware overcurrent		
0702	S-phase inverter hardware overcurrent		
0703	T-phase inverter hardware overcurrent		
0704	Bridge arm overcurrent		
0801	R-phase inverter overvoltage		
0802	S-phase inverter overvoltage		
0803	T-phase inverter overvoltage		

Defect codes	Defect name	Fault cause	Solutions
1501	Control board overtemperature	1. Inverter installation location is not ventilated. 2. Ambient temperature is too high.	1. Check whether the ventilation of the inverter installation position is good and whether the ambient temperature exceeds the maximum allowable ambient temperature range. 2. If there is no ventilation or the ambient temperature is too high, please improve its ventilation and heat dissipation. 3. Check whether the fan is working normally and whether the air duct is blocked or blocked by dust?
1504	Inverter module overtemperature		
1505	Control board NTC not connected	Temperature detection circuit abnormality.	Disconnect the AC circuit breaker and photovoltaic input switch in turn, and then close the AC circuit breaker and photovoltaic input switch in turn after 10 minutes to check whether the fault persists?
1508	Inverter module NTC not connected		
1801	PV1 overvoltage	Photovoltaic array configuration errors, excessive number of photovoltaic panels in series.	Check the series configuration of the corresponding photovoltaic array string to ensure that the open circuit voltage of the string is not higher than the maximum operating voltage of the inverter. ASN-(30~40)TL-LV-G2≤800V ASN-(50~80)TL-G2≤1100V
...	...		
1812	PV12 overvoltage		
1901	PV input software overcurrent	1. Unreasonable component configuration. 2. Abnormal changes in illumination.	1. Please check whether the AC connection line is correctly connected according to the wiring requirements of the manual. 2. Disconnect the AC circuit breaker, and photovoltaic input switch in turn. After 10 minutes, close the AC circuit breaker and photovoltaic input switch in turn to check whether the fault is still the same.
2001	PV input hardware overcurrent		
2101	PV input arcing fault	1. DC string connection terminals are not securely connected. 2. DC wiring is damaged.	Please check whether the component cables are properly connected according to the wiring requirements in the manual.



Defect codes	Defect name	Fault cause	Solutions
2201	PV1 reverse connection	DC string connections are reversed.	Turn off the AC circuit breaker and photovoltaic input switch in turn. After the inverter is turned off, adjust the DC ancestral positive and negative wiring, turn off the AC circuit breaker and photovoltaic input switch in turn to check whether the fault is still the same?
...	...		
2212	PV12 reverse connection		
2301	PV1 short circuit	Short circuit phenomenon in the DC string.	Disconnect the AC circuit breaker and photovoltaic input switch in turn, and close the AC circuit breaker and photovoltaic input switch in turn after 10 minutes to check whether the fault persists?
...	...		
2312	PV12 short circuit		
2401	Internal fan fault	1. Abnormal fan power supply. 2. Mechanical failure (blocked rotation). 3. Fan aging and damage.	Check whether the fan is working properly, whether the air duct is blocked or blocked by dust.
2402	External fan fault		
2501	First-order overvoltage (lowest voltage)	Power grid voltage exceeds or falls below the allowable range.	1. If it happens accidentally, it may be that the power grid is abnormal for a short time. The inverter will return to normal operation after detecting that the power grid is normal, without manual intervention. 2. If it appears frequently, please check whether the grid voltage is within the allowable range. • If the grid voltage is outside the allowable range, contact your local electricity operator. • If the grid voltage is within the allowable range, it is necessary to modify the inverter after obtaining the consent of the local power operator, and the grid protection point . 3. If it cannot be recovered for a long time, please check whether the AC side circuit breaker and the output cable are connected normally.
2502	Second-order overvoltage		
2503	Third-order overvoltage		
2504	10 minutes overvoltage		
2505	First-order undervoltage		
2506	Second-order undervoltage		
2507	Third-order undervoltage		
2508	Line voltage first-order overvoltage		

Defect codes	Defect name	Fault cause	Solutions
2509	Line voltage second-order overvoltage	Power grid voltage exceeds or falls below the allowable range.	<p>1. If it happens accidentally, it may be that the power grid is abnormal for a short time. The inverter will return to normal operation after detecting that the power grid is normal, without manual intervention.</p> <p>2. If it appears frequently, please check whether the grid voltage is within the allowable range.</p> <ul style="list-style-type: none"> • If the grid voltage is outside the allowable range, contact your local electricity operator. • If the grid voltage is within the allowable range, it is necessary to modify the inverter after obtaining the consent of the local power operator, and the grid protection point. <p>3. If it cannot be recovered for a long time, please check whether the AC side circuit breaker and the output cable are connected normally.</p>
2510	Line voltage third-order overvoltage		
2511	Line voltage first-order undervoltage		
2512	Line voltage second-order undervoltage		
2513	Line voltage third-order undervoltage		
2601	First-order overfrequency (lowest frequency)	Power grid frequency exceeds or falls below the allowable range.	<p>1. If it happens accidentally, it may be that the power grid is abnormal for a short time. The inverter will return to normal operation after detecting that the power grid is normal, without manual intervention.</p> <p>2. If it appears frequently, please check whether the grid frequency is within the allowable range.</p> <ul style="list-style-type: none"> • If the grid frequency is outside the allowable range, contact the local electricity operator. • If the grid frequency is within the allowable range, it is necessary to modify the inverter grid protection point. <p>3. after obtaining the consent of the local power operator. If it cannot be recovered for a long time, please check whether the AC side circuit breaker and the output cable are properly connected.</p>
2602	Second-order overfrequency		
2603	Third-order overfrequency		
2604	First-order underfrequency		
2605	Second-order underfrequency		
2606	Third-order underfrequency		

Defect codes	Defect name	Fault cause	Solutions
2701	Islanding fault	The power grid has been disconnected, and due to the presence of a load maintaining the grid voltage, grid-tied operation is stopped according to safety regulations to protect requirements.	Wait for the grid to return to normal after the machine will be connected again.
2901	ISO fault	<ol style="list-style-type: none"> 1. Photovoltaic strings short-circuit to the protective ground. 2. The installation environment of the photovoltaic strings is chronically humid and the line insulation to the ground is poor. 	<ol style="list-style-type: none"> 1. Check the impedance of the photovoltaic string to the protection ground. It is normal that the resistance value is greater than 50kΩ. If the resistance value is less than 50kΩ, please check the short circuit point and rectify it. 2. Check whether the protective earth wire of the inverter is connected correctly.
3001	GFCI sensor fault	Leakage current sensor sampling abnormality.	Disconnect the AC circuit breaker and photovoltaic input switch in turn, and then close the AC circuit breaker and photovoltaic input switch in turn after 10 minutes to check whether the fault persists?
3002	GFCI fault	<ol style="list-style-type: none"> 1. Photovoltaic strings or AC lines short-circuit to the protective ground. 2. Electrical equipment has leakage current. 3. The machine installation environment is chronically humid and the line insulation to the ground is poor. 	<ol style="list-style-type: none"> 1. Confirm whether the insulation of photovoltaic string and AC line is normal? 2. Check whether there is leakage current in electrical equipment?
3101	Auxiliary source abnormality	Power circuit fault.	Disconnect the AC circuit breaker and photovoltaic input switch in turn. After removing the external communication cable, data acquisition rod and other equipment, close the AC circuit breaker and photovoltaic input switch in turn, check if the fault persists?

Defect codes	Defect name	Fault cause	Solutions
3301	Relay fault	1. Relay abnormality (relay short circuit). 2. Control circuit abnormality. 3. Abnormal AC side wiring (possible virtual connection or short circuit).	1. Please check whether the AC connection line is correctly connected according to the wiring requirements of the manual. 2. Disconnect the AC circuit breaker and photovoltaic input switch in turn. After 10 minutes, close the AC circuit breaker, and photovoltaic input switch, check if the fault persists?
4001	Grid voltage detection inconsistency	Control circuit abnormality.	Disconnect the AC circuit breaker and photovoltaic input switch in turn, close the AC circuit breaker and photovoltaic input switch in turn after 10 minutes to check whether the fault still does not need to be handled.
4002	BUS voltage detection inconsistency		
4003	GFCI detection inconsistency		
4201	DRM shutdown	Responding to dispatch shutdown.	If you have any questions, please contact the installer.
4202	Command shutdown		
4203	Remote Lockout		

6.8 Regular maintenance

	Danger: The machine must be kept power off state during maintenance.
	Watch out: Regular maintenance can maintain the stability of inverter performance.

Content	Method	Cycle
System cleaning	Check the cooling fin and air inlet/outlet for foreign matter and dust. Especially the fan needs regular maintenance to prevent debris from blocking the fan and affecting the operation of the inverter.	half year
DC switch	Turn on and off the DC switch for 10 times continuously to ensure the normal function of DC switch.	one year
Electrical connection	Check whether the electrical connection is loose, whether the cable appearance is damaged and whether there is copper leakage.	half year
Tightness	Check whether the tightness of the equipment inlet hole meets the requirements. If the gap is too large or not sealed, it shall be re-closed.	one year

7 TECHNICAL PARAMETER

Model	ASN-50TL-G2	ASN-60TL-G2	ASN-70TL-G2	ASN-75TL-G2	ASN-80TL-G2
Input DC					
Max.input power	75kW	90kW	105kW	112.5kW	120kW
Max.input voltage	1100V				
Rated voltage	630V				
MPPT voltage range	150-1000V				
Start-up voltage	180V				
MPPT number	4				
Max.input strings number	8	12	12	12	12
Max.input current	4 x 40A	4 x 48A	4 x 48A	4 x 48A	4 x 48A
Max.short circuit current	4 x 50A	4 x 60A	4 x 60A	4 x 60A	4 x 60A
Output AC					
Rated output power	50kW	60kW	70kW	75kW	80kW
Max.apparent output power	55kVA	66kVA	77kVA	82.5kVA	88kVA
Max.output power	55kW	66kW	77kW	82.5kW	88kW
Rated grid voltage	220V/380V,230V/400V,3/N/PE				
Grid voltage range	162-300V(Phase voltage),280-520V(Line voltage)				
Rated grid frequency	50/60Hz				
Rated output current	72.2A	86.6A	101A	108.3A	115.5A
Max.output current	79.4A	95.3A	111A	119.1A	127A
Power factor	>0.99 (0.8 leading ... 0.8 lagging)				
THDi	<3%				
Efficiency					
Max. efficiency	98.60%				
EU efficiency	98.30%				
MPPT efficiency	>99.80%				

Model	ASN-30TL-LV-G2	ASN-40TL-LV-G2
Input DC		
Max.input power	45kW	60kW
Max.input voltage	800V	
Rated voltage	360V	
MPPT voltage range	150-800V	
Start-up voltage	180V	
MPPT number	4	
Max.input strings number	12	
Max.input current	4 x 48A	4 x 48A
Max.short circuit current	4 x 60A	4 x 60A
Output AC		
Rated output power	30kW	40kW
Max.apparent output power	33kVA	44kVA
Max.output power	33kW	44kW
Rated grid voltage	127V/220V,3/N/PE	
Grid voltage range	92-173V(Phase voltage),160-300V(Line voltage)	
Rated grid frequency	50/60Hz	
Rated output current	78.7A	105A
Max.output current	86.6A	115.5A
Power factor	>0.99 (0.8 leading ... 0.8 lagging)	
THDi	<3%	
Efficiency		
Max. efficiency	98.60%	
EU efficiency	98.00%	
MPPT efficiency	>99.80%	

Protection	
Integrated DC switch	Yes
DC rever-polarity protection	Yes
Anti-islanding protection	Yes
Short circuit protection	Yes
Output over current protection	Yes
DC Surge protection	Type II
AC Surge protection	Type II
Insulation impedance detection	Yes
Ground fault monitoring	Yes
Residual leakage current detection	Yes
Temperature protection	Yes
AC Over voltage protection	Yes
DC Over current protection	Yes
Strings monitoring	Optional
24-hour load monitoring	Optional
Integrated AFCI (DC arc-fault circuit protection)	Optional
Integrated PID recovery	Optional
Antibackflow	Optional
I/V Curve scanning	Optional

General Data	
Dimensions (W x H x D)	735 x 530 x 285 mm
Weight *[1]	60kg
Self consumption(night)	< 1W
Operating temperature range	-30 ... +60°C
Cooling concept	fan-cooling
Max.operation altitude	4000m (Derating above 3000m)
Relative humidity	0-100%
Protective class	I
Ingress protection	IP66
Topology structure	Transformerless
Grid connection stadard	NB/T 32004, EN 50549-1, IEC 63027, PORTARIA N°515
Safety/EMC standard	IEC/EN 62109-1/2, EN IEC 61000-6-1/2/3/4, EN IEC 61000-3-11, EN 61000-3-12
Type of DC terminal	MC4 connector
Type of AC terminal	OT terminal
Display & Communication	
Display	LED+Bluetooth+APP (Optional:LCD)
Communication interface	RS485, Optional:WIFI, 4G, LAN

The product may be update in the future. The above parameters are for reference only. Please refer to the real thing.
*[1]:The weight parameters here are for reference only, and the actual weight shall prevail outside the box or official website.

(此页不打印)

打印说明:

- 1、页面按页码调整为中缝装订，对折后成品页面尺寸：142.5x210mm，成品展开尺寸公差 ± 3 mm;
- 2、封面封底157g铜版纸打印；注：正面印刷，反面不要印刷内容.
- 3、正文内容80g双胶纸，双面黑白打印；
- 4、图面、字体印刷清晰，无乱码、无偏移、无毛边、不起边、油墨不脱落；
- 5、符合RoHs.